

SECTION 18

BODY

A. Body Sheet Metal	18- 1
B. Bonnet and Rear Compartment Lid	18- 4
C. Front Fender and Splash Guard	18- 7
D. Front Grill and Bumper	18- 8
E. Door	18-10
F. LN360 Tail Gate	18-17
G. Windshield Glass	18-20
H. Windshield Washer	18-21
I. Quarter Window Glass	18-23
J. Standard Instrument Panel	18-24
K. Deluxe Instrument Panel	18-30
L. Body Accessory	18-34
M. Special Tool	18-35

A. Body Sheet Metal

Honda N series sedans and vans are of the monocoque construction type designed for high rigidity with minimum weight. When the car has an accident and the body is twisted or cracked, a thorough knowledge of body construction and welding seams are essential for body repairing.

The following is the picture and the list of the available body sheet metal components.

BODY SHEET METAL COMPONENTS OF N SERIES SEDANS

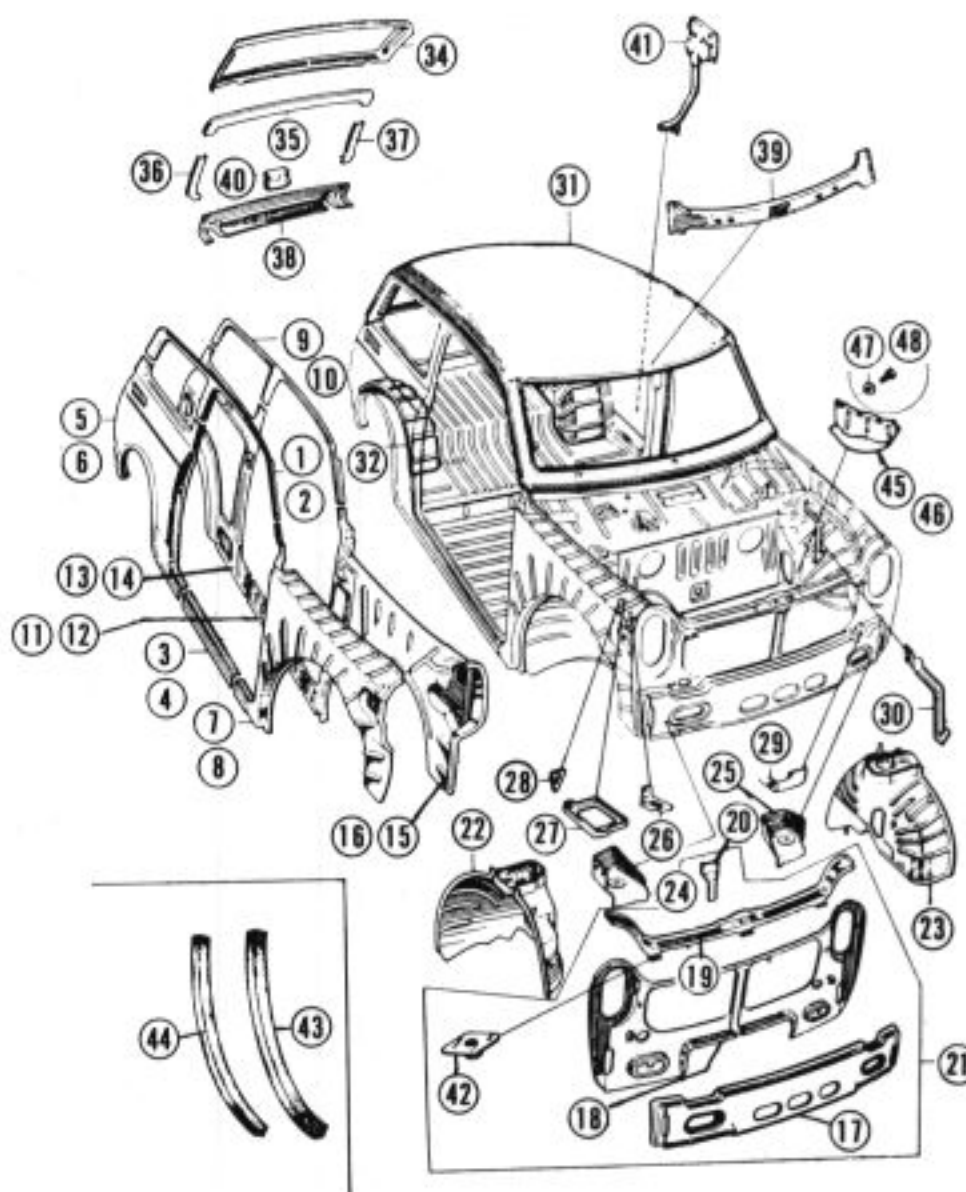

Ref. No.	Description
1.	Roof side edge outer panel R
2.	Roof side edge outer panel L
3.	Door sill outer panel R
4.	Door sill outer panel L
5.	Rear fender outer panel R
6.	Rear fender outer panel L
7.	Front fender middle panel R
8.	Front fender middle panel L
9.	Roof side edge inner panel R
10.	Roof side edge inner panel L
11.	Door sill inner panel R
12.	Door sill inner panel L
13.	Rear fender inner panel R
14.	Rear fender inner panel L
15.	Front fender inner panel R
16.	Front fender inner panel L
17.	Front skirt panel
18.	Front end bulkhead
19.	Front end tie member
20.	Tie member stiffener
21.	Front end bulkhead assembly
22.	Front wheel housing R
23.	Front wheel housing L
24.	Sub-frame front bracket R
25.	Sub-frame front bracket L
26.	Battery stay bracket
27.	Battery stay
28.	Battery stay rear bracket
29.	Fuel pump bracket
30.	Spare tire support
31.	Roof panel
32.	Rear wheel housing R
33.	Rear wheel housing L
34.	Luggage compartment opening frame

Fig. 18A-1

UNDER BODY ALIGNMENT (Unit: mm)

After the damaged area is repaired, the underbody should be always checked with utmost accuracy and any distortion should be corrected as specified in Fig. 18A-2a (standard) and Fig. 18A-2b (American Type)

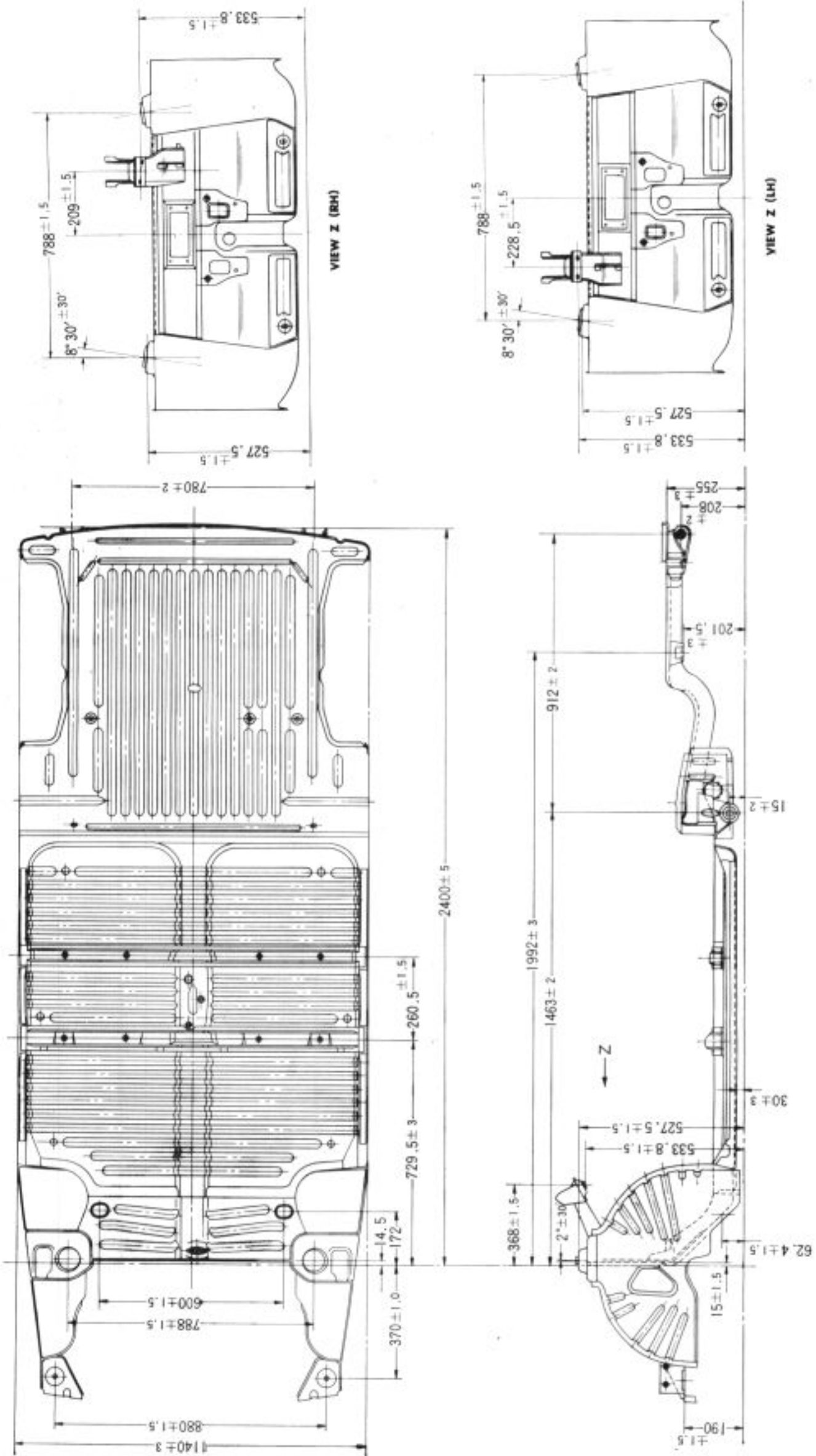

Fig. 18A-2a Standard

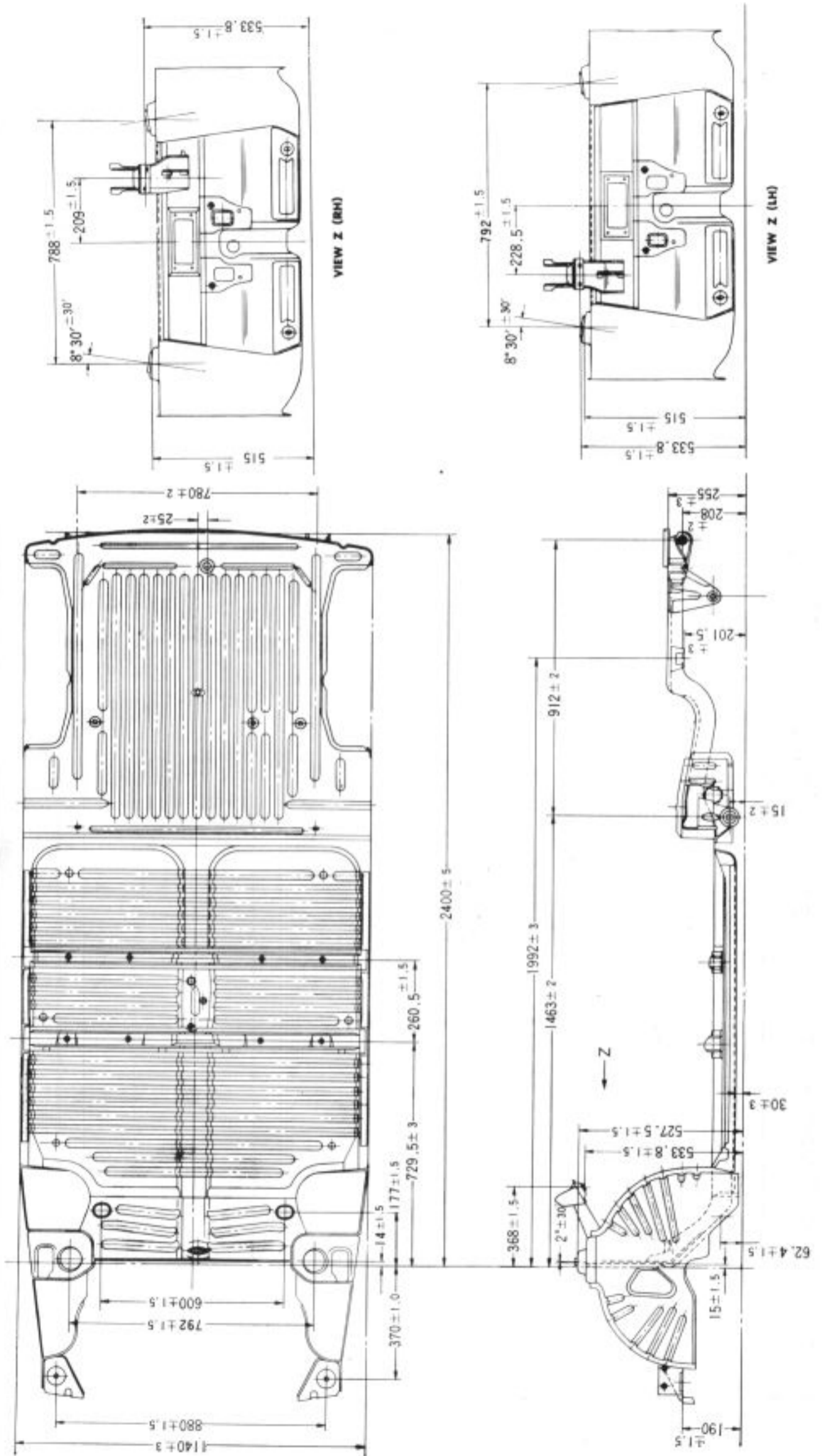

Fig. 18A-2b American Type

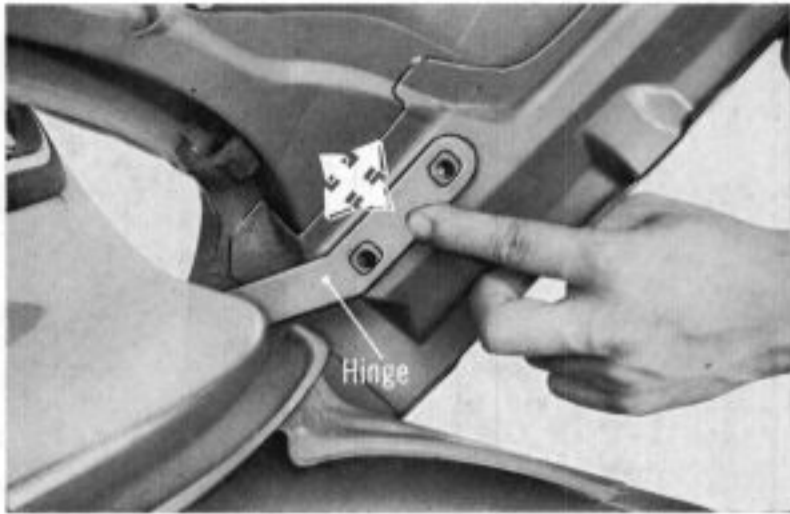

Fig. 18B-1

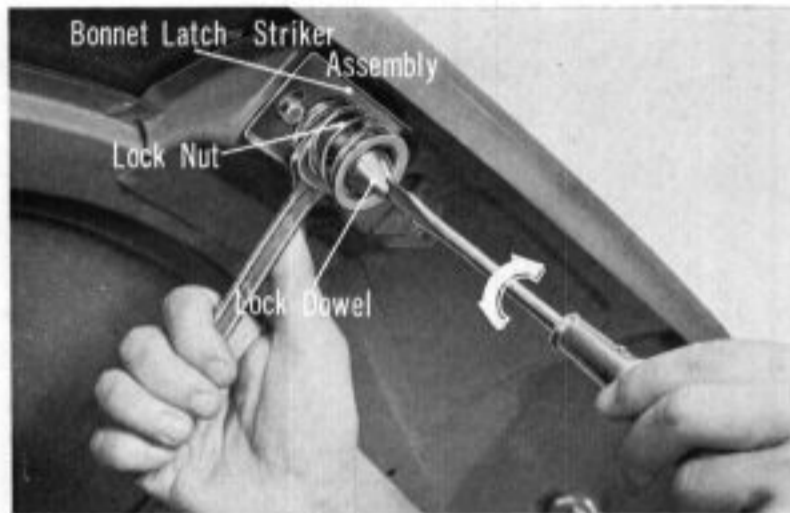

Fig. 18B-2

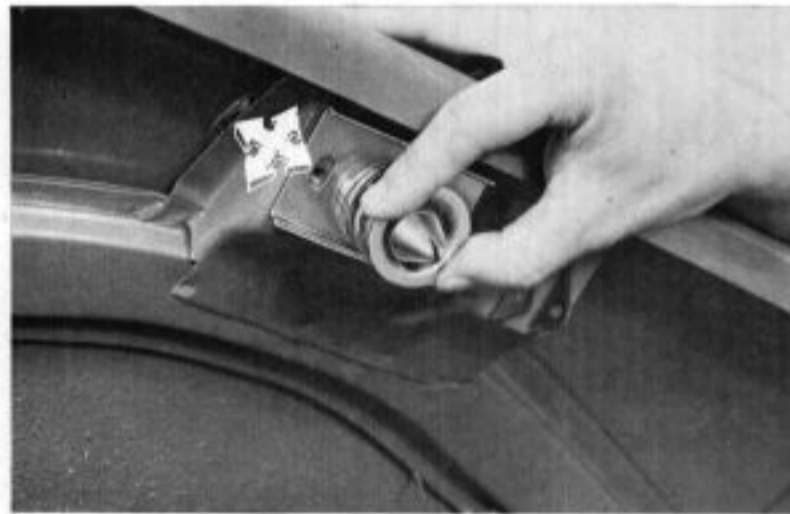

Fig. 18B-3



Fig. 18B-4

B. Bonnet and Rear Compartment Lid

a. BONNET

The installation or removal of the bonnet is made with four mounting bolts at both left and right hinges.

For adjustment of the bonnet position to the fore and aft, right and left, or up and down, large hinge holes are used. Adjust the bonnet position and retighten the bolts.

Loosen the lock nut on the bonnet lock dowel and turn the dowel inward to adjust the bonnet tighten or outward to adjust loosen.

Improper bonnet opening and closing may be due to poor lock dowel and bonnet latch hole center alignment. The bonnet latch striker can be slid freely all directions. Loosen mounting bolts and adjust by sliding the bonnet latch striker.

Grease upon completion of adjustment.
Also check the bonnet safety catch for security.

b. REAR COMPARTMENT LID

The rear compartment is made of ABS resin and suspended by two hinges.

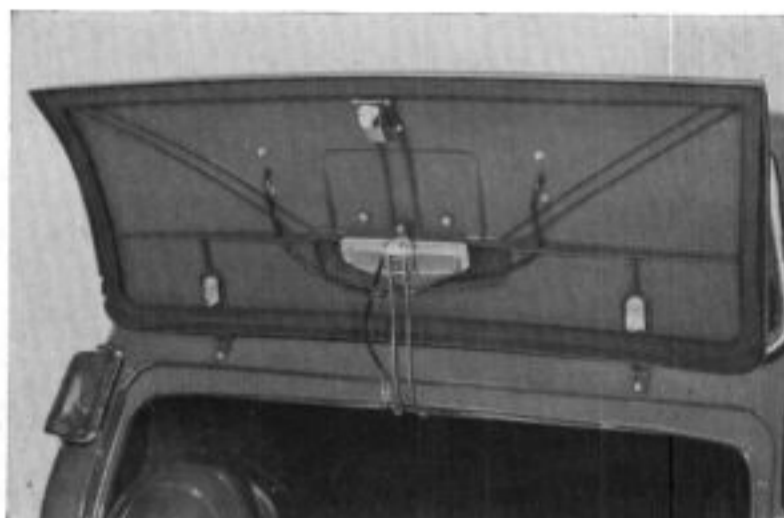

Fig. 18B-5

To disassemble the lid make the lid open stay narrower to separate it from the body, and disconnect the leads of the license plate light.

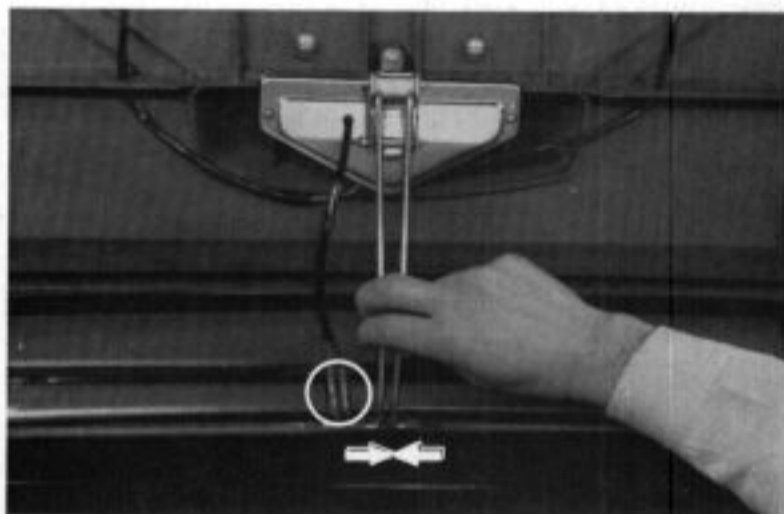

Fig. 18B-6

Unscrew the nuts of both the right and left hinges, and remove the mounting washer to separate the rear compartment lid from the hinges.



Fig. 18B-7

For assembly, note the holes of the rear compartment lid are made large so that the lid position can be adjusted horizontally and laterally.



Fig. 18B-8

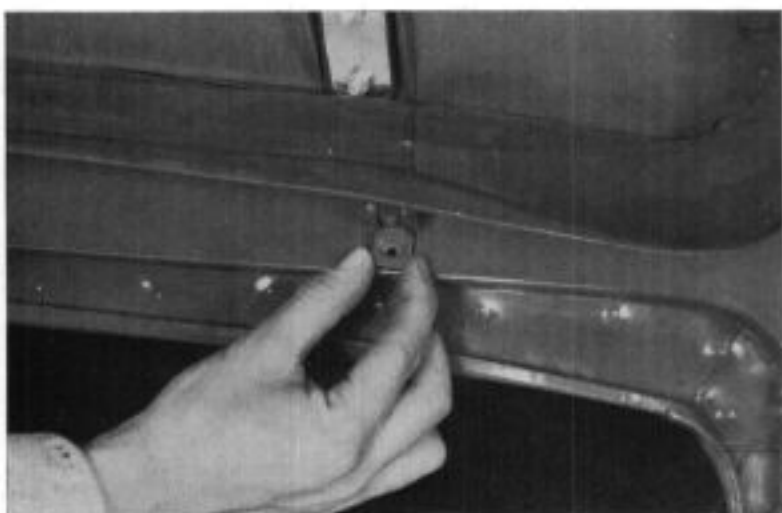

Fig. 18B-9

The adjustment of the lid position in the horizontal direction can also be made with the male hinge.



Fig. 18B-10

Check the rear compartment lid for improper closing by dropping from the horizontal open position. If the lid shuts completely and the opening is not firm, the trunk lid lock and the trunk lid catch are proper.

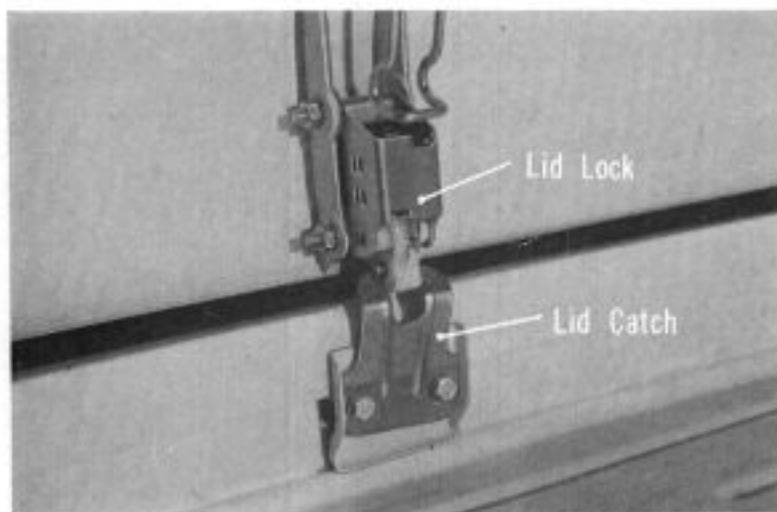

Fig. 18B-11

Improper lid closing is due either defective trunk lid lock or improper position of the trunk lid lock catch. If the lid does not close completely and opening/closing is not firm, slide the trunk lid lock catch downward (Fig. 18B-12) or bend inward with a hammer. (Fig. 18B-13)

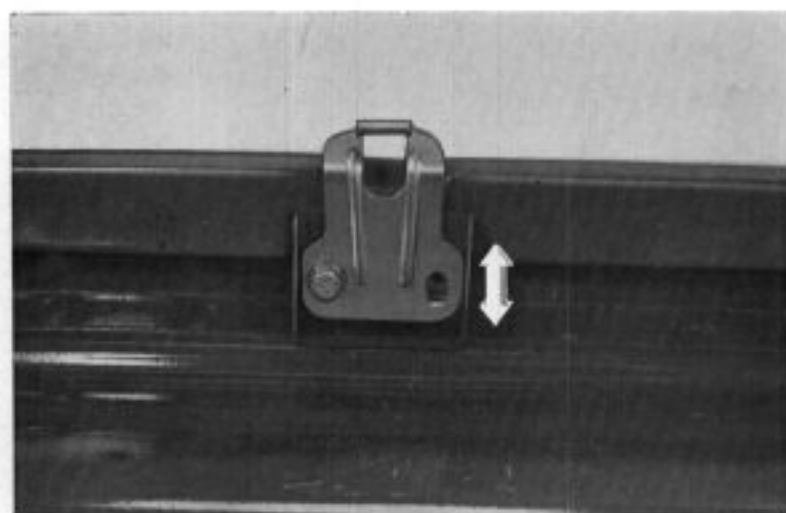

Fig. 18B-12

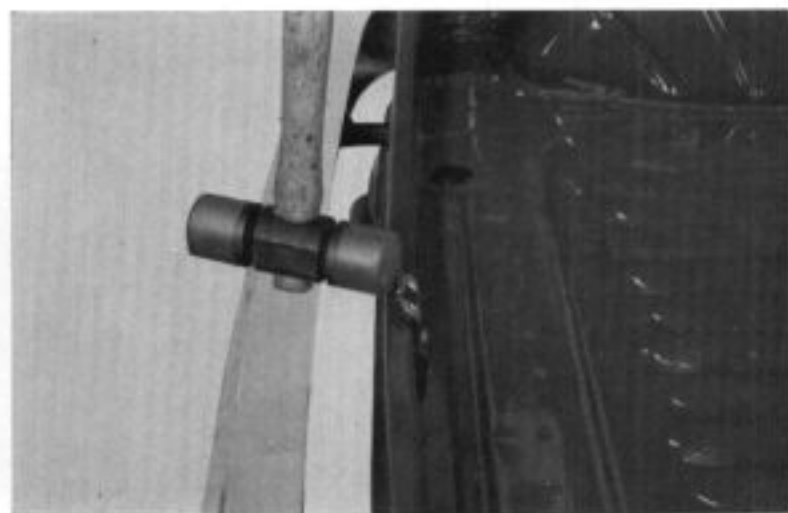

Fig. 18B-13

C. Front Fender and Splash Guard Plate

Splash guard plate is mounted on the body with three 6mm bolts, and prevents water from entering the engine room. (only for the vehicle equipped with engine type car heater.)

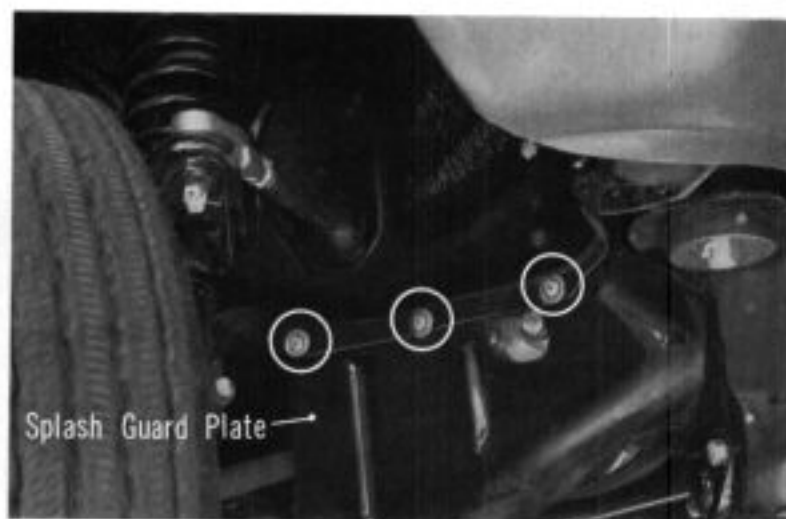

Fig. 18C-1

Front fender is secured to the body with eight bolts.

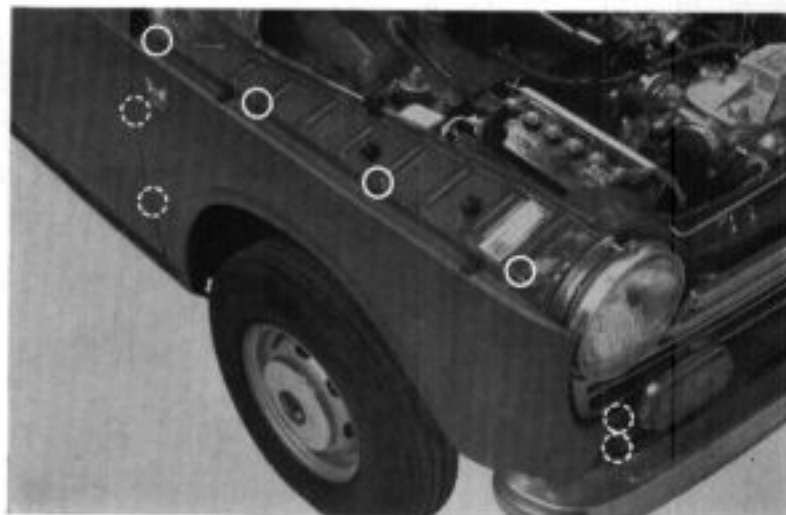

Fig. 18C-2

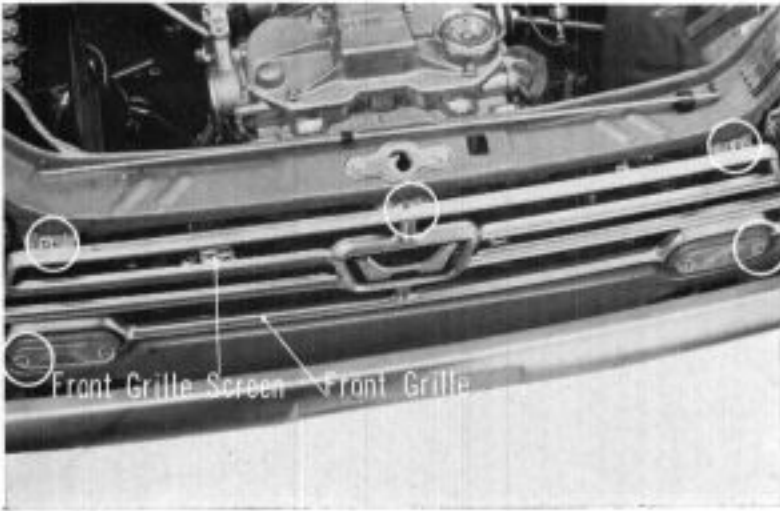

Fig. 18D-1

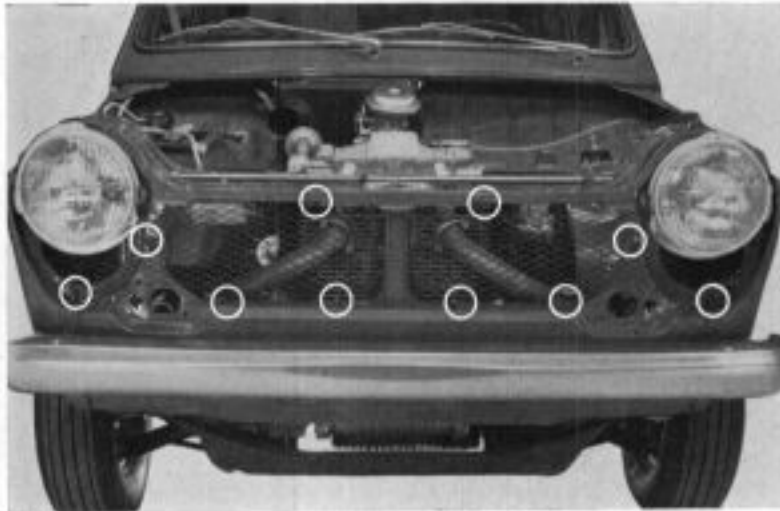

Fig. 18D-2

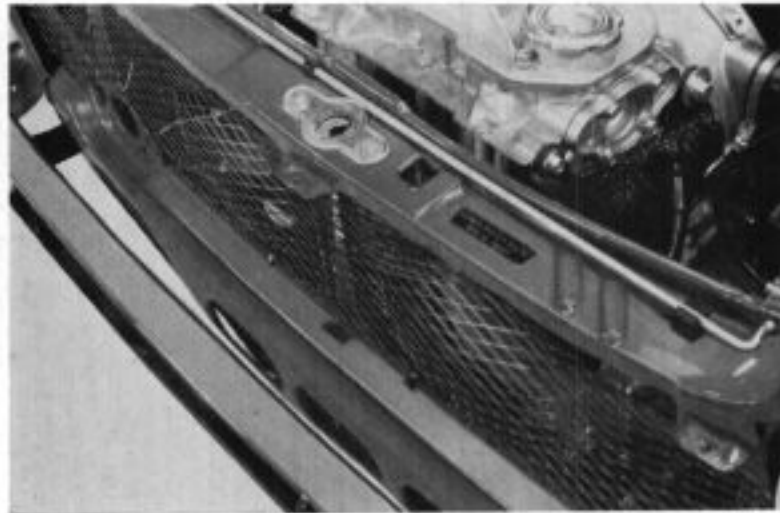

Fig. 18D-3



Fig. 18D-4

D. Front Grille and Bumpers

a. FRONT GRILLE

Remove the front grille and front grille screen by removing the five retaining screws.

Unbend the lock plate to remove the screen.

N600: When installing the screen, note the convex side faces outward to avoid the exhaust pipes.

Insert the front grille into a body slit with a mounting cushion.

b. FRONT BUMPER

Front bumper is secured with four mounting bolts. Do not damage the silicon rectifier when bolting or unbolting.



Fig. 18D-5

Bumper guard is supported at the front bulkhead with a bracket. (U.S.A. only)

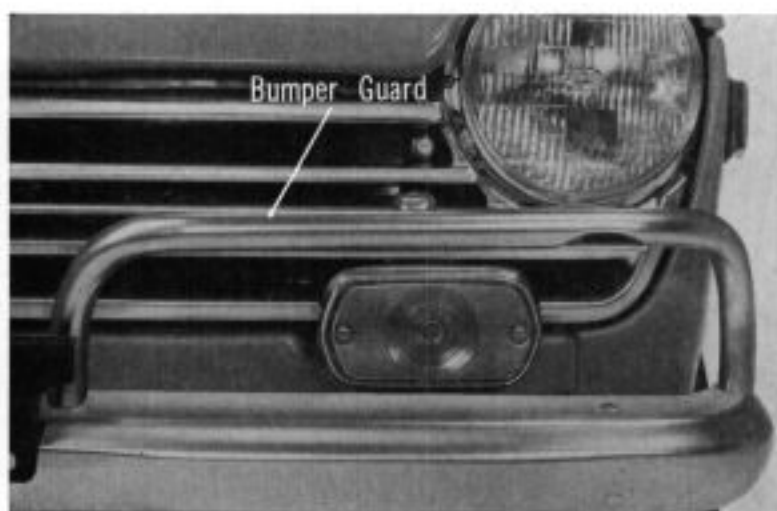

Fig. 18D-6

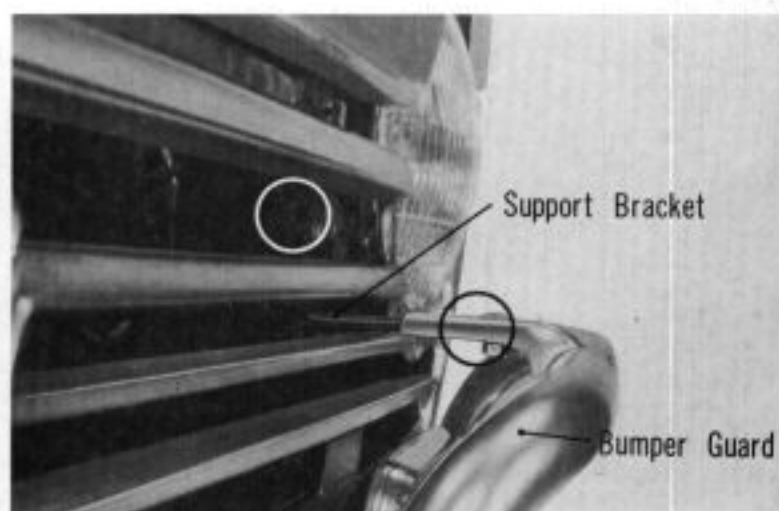

Fig. 18D-7

c. REAR BUMPER

The rear bumper is also assembled to the body through bumper stay and secured with four bolts.



Fig. 18D-8

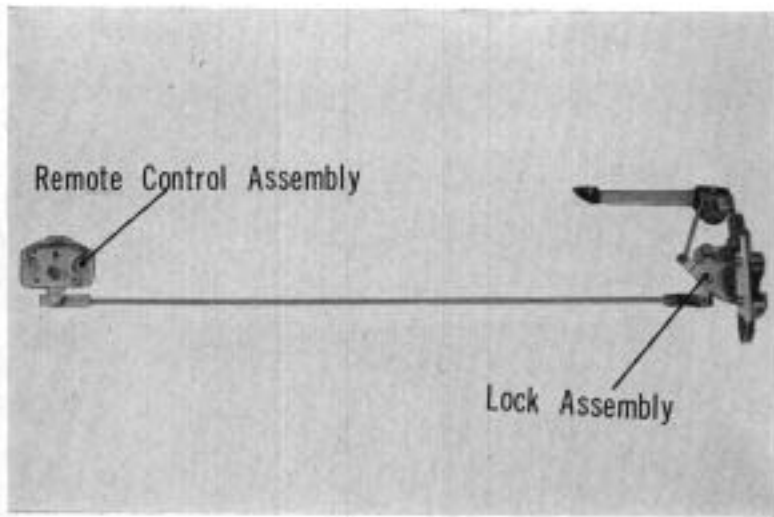

Fig. 18E-1

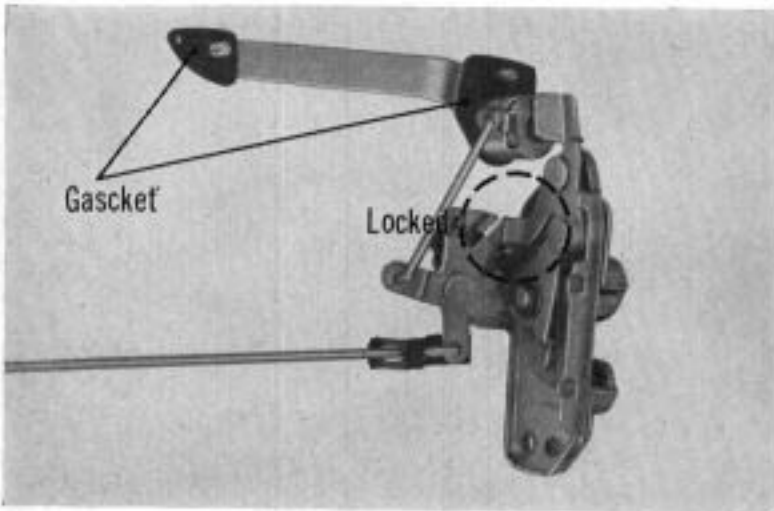

Fig. 18E-2

E. Door Assembly

1. Apply grease both to the remote control assembly and lock assembly. Then, join the lock assembly to the remote control assembly,



Fig. 18E-3

2. Install the remote control assembly and the lock assembly in a single unit in the door. Check the operation of the door lock. Then, install a piece of sponge suchion at the middle of the lock control rod.

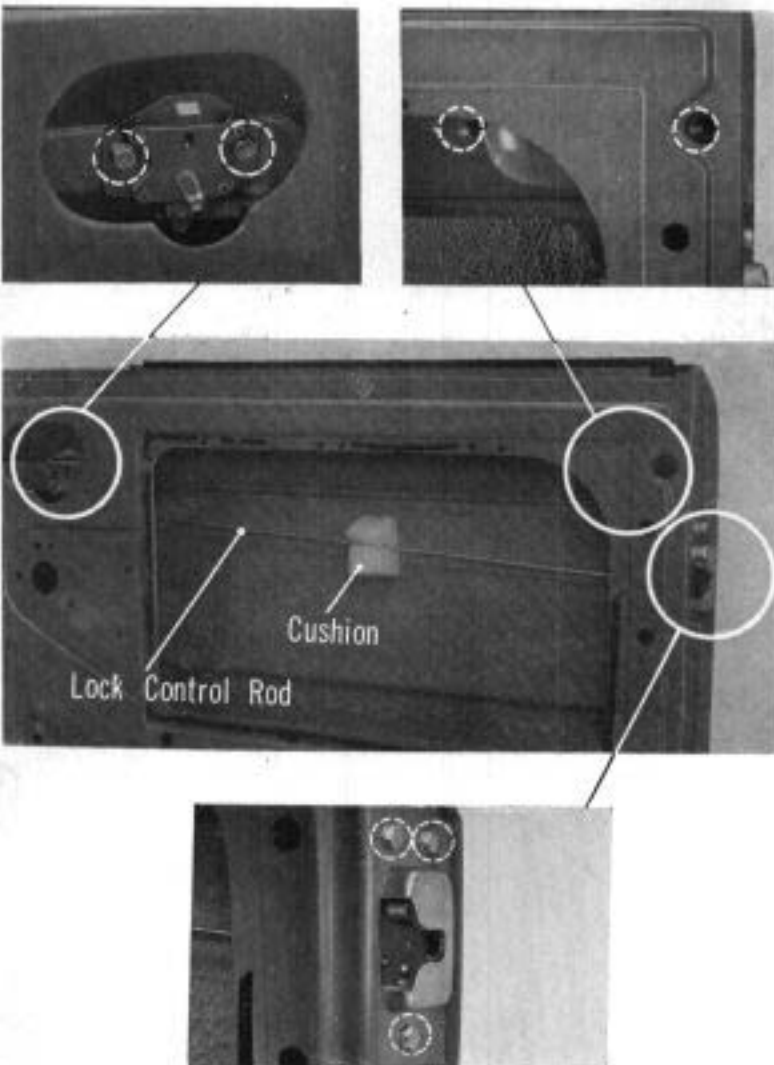

Fig. 18E-4

3. There are two types of regulator. (Fig. 18E-5 and Fig. 18E-6)

Mount the door window regulator assembly on the door with seven screws. Do not deform the regulator. If the regulator is deformed, window action becomes tight. Apply a coating of grease on the regulator in advance.

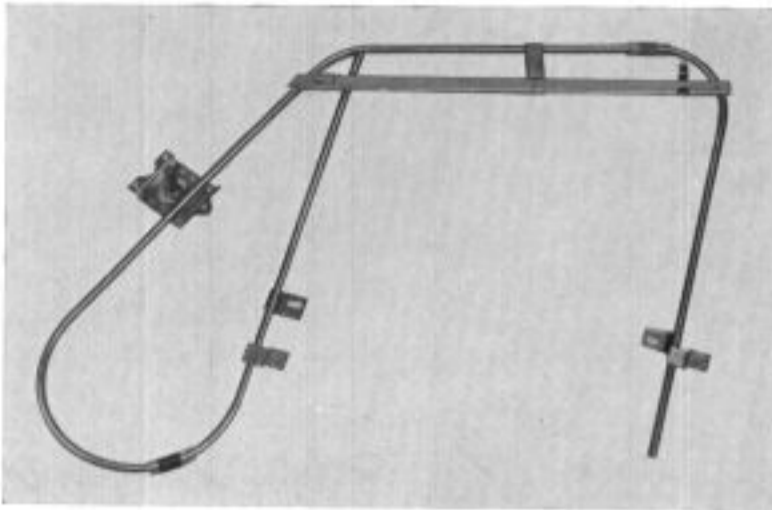

Fig. 18E-5-Type A

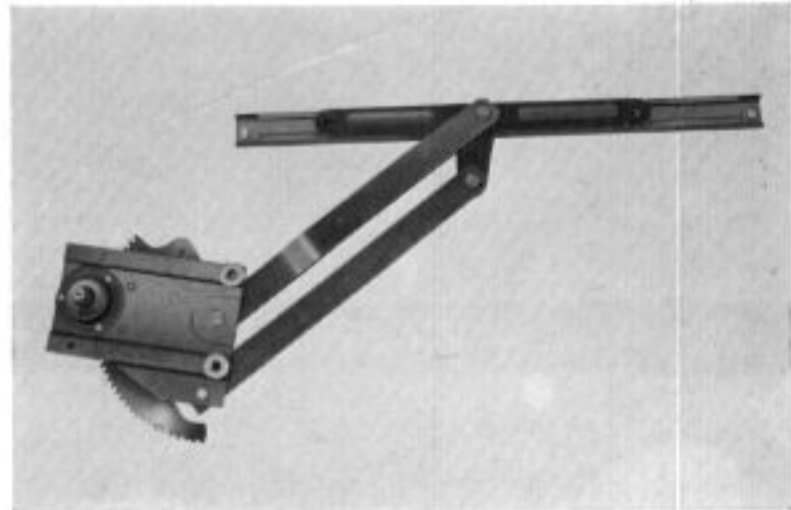

Fig. 18E-6-Type B

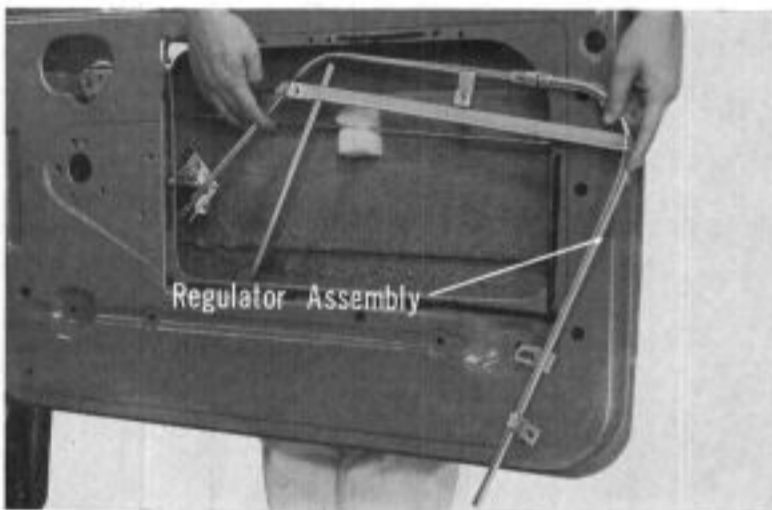

Fig. 18E-7

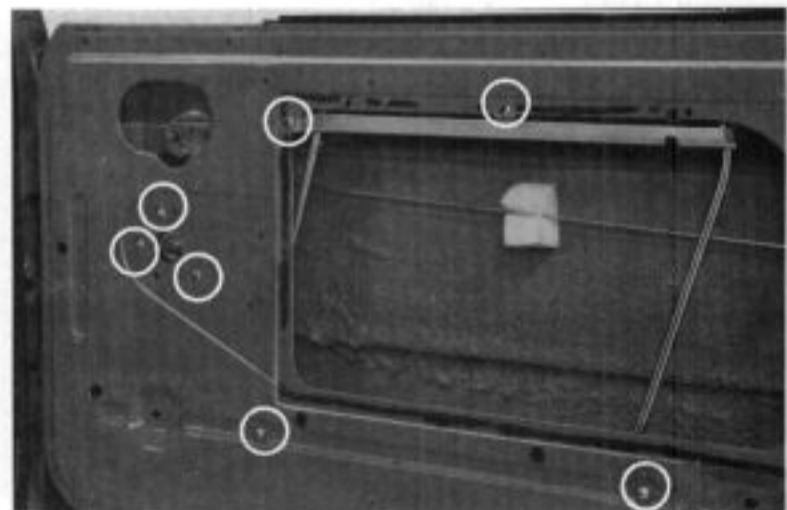

Fig. 18E-8

4. Check the ventilator glass open/close action. Adjust with nuts if necessary.

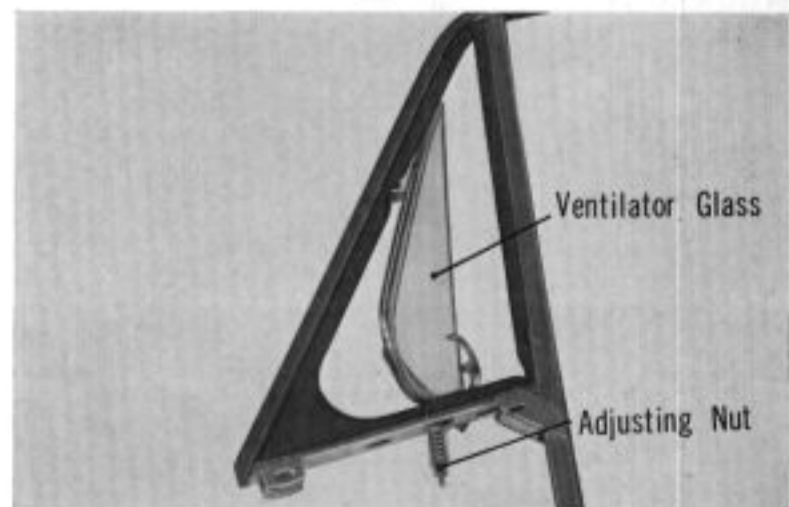

Fig. 18E-9

18-12 BODY



Fig. 18E-10

5. With the door glass fitted to the door sash, place it on the door.
Do not drop the glass.

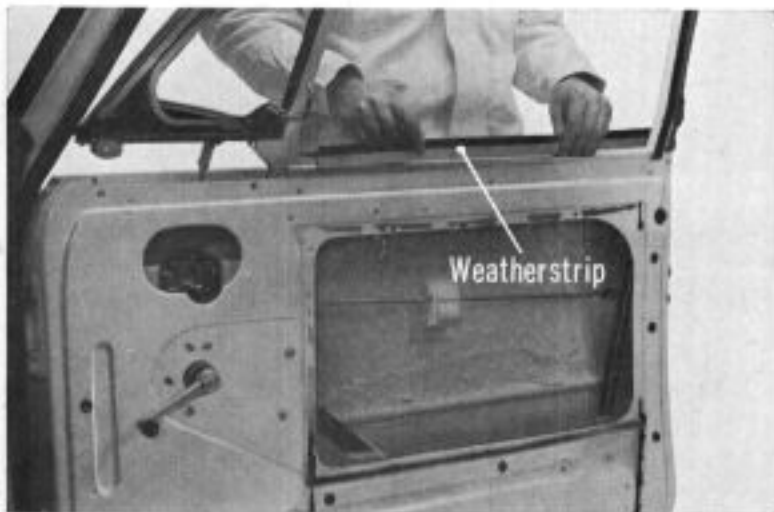

Fig. 18E-11

6. Check the outer weather strip clips for proper contour and reform if necessary.
Drop the door glass carefully and install the outer weather strip.

7. Temporarily install the window regulator handle, turn it, and raise the door glass holder mounting part as shown (X) in Fig. 18E-12 and Fig. 18E-13, and join with the glass. Secure the door sash with five bolts. (Fig. 18E-12)

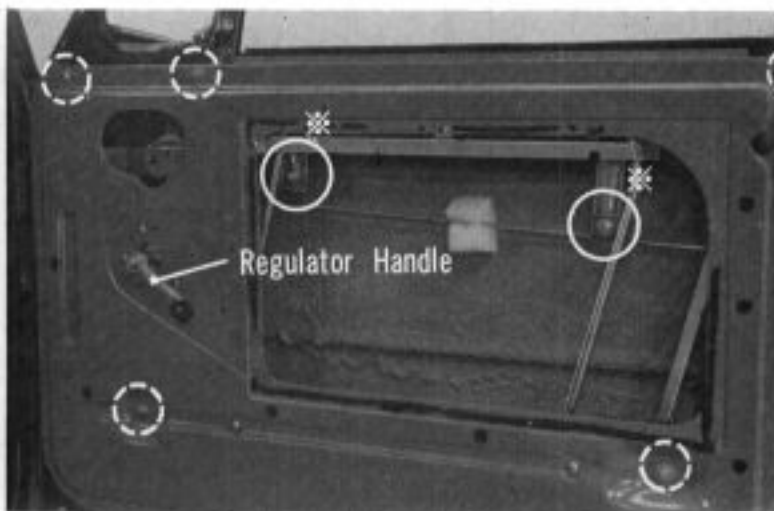

Fig. 18E-12-Type A

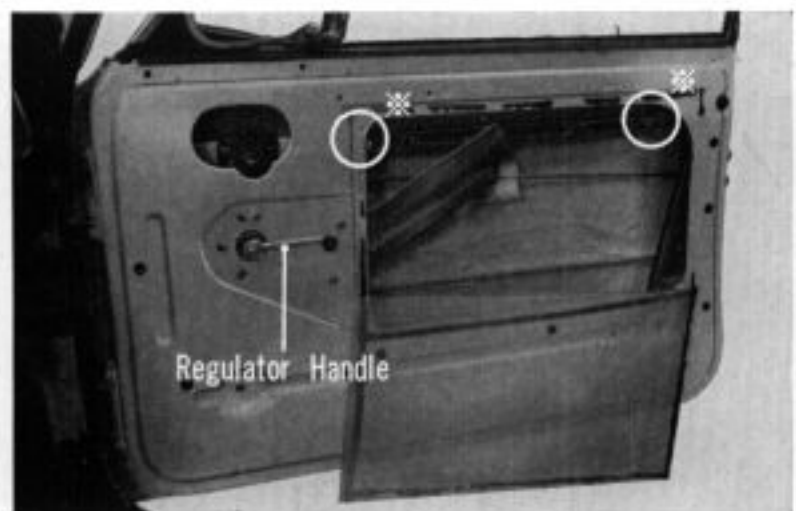

Fig. 18E-13-Type B

8. Upon completion of sash setting, turn the regulator handle and insure that glass action is normal and light.



Fig. 18E-14

9. Seal the panel with vinyl film as shown.

Note:

Stretch the door panel center seal so that no wrinkle occurs in the seal. Wrinkle may cause water leakage.

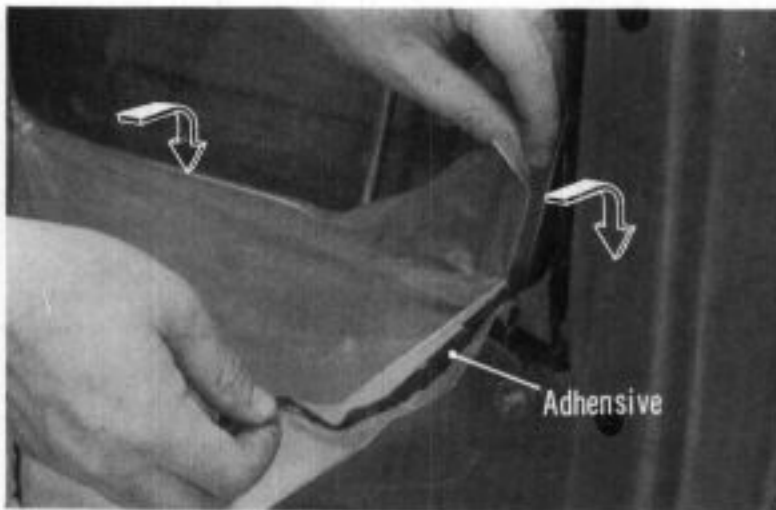

Fig. 18E-15

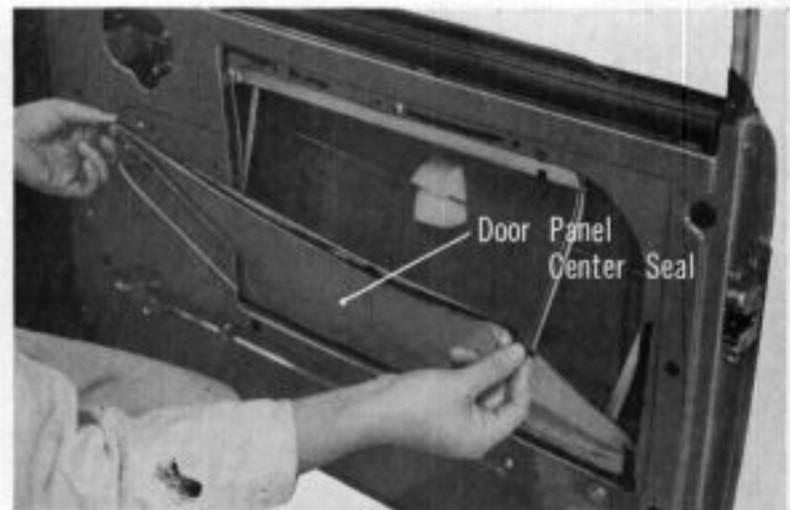

Fig. 18E-16

10. Place the inner weatherstrip and secure with the garnish.

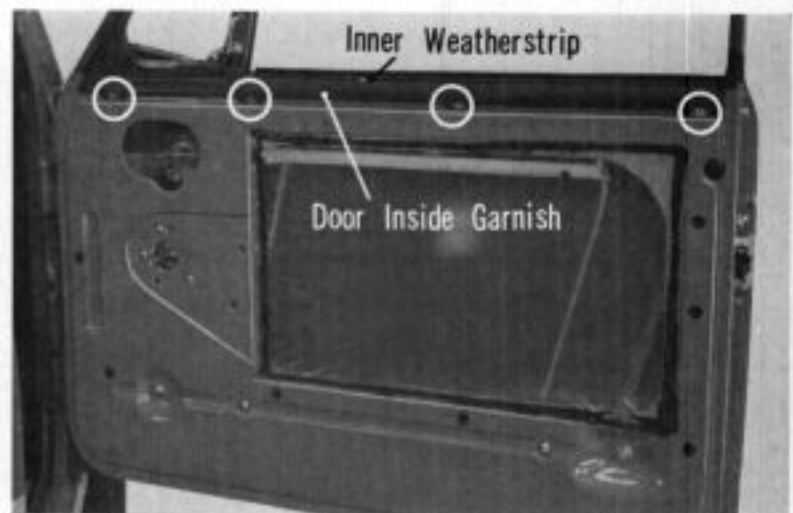

Fig. 18E-17

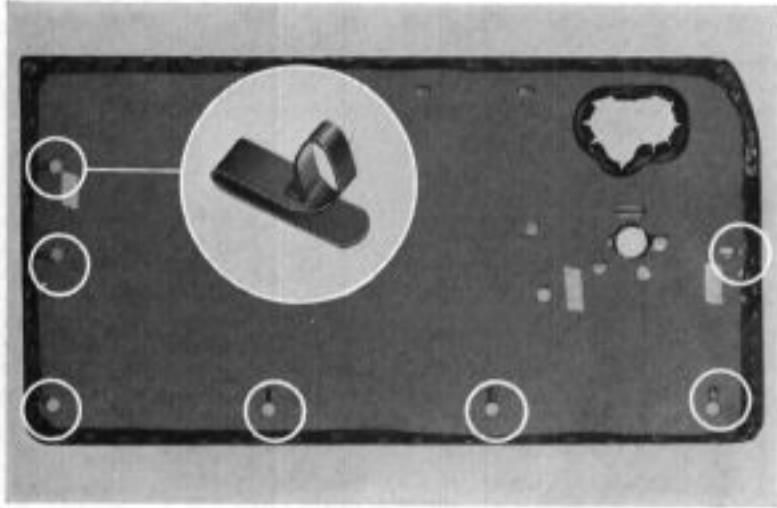

Fig. 18E-18

11. Check door lining clips for proper countour and reform if necessary.
Then, install the lining to the door.

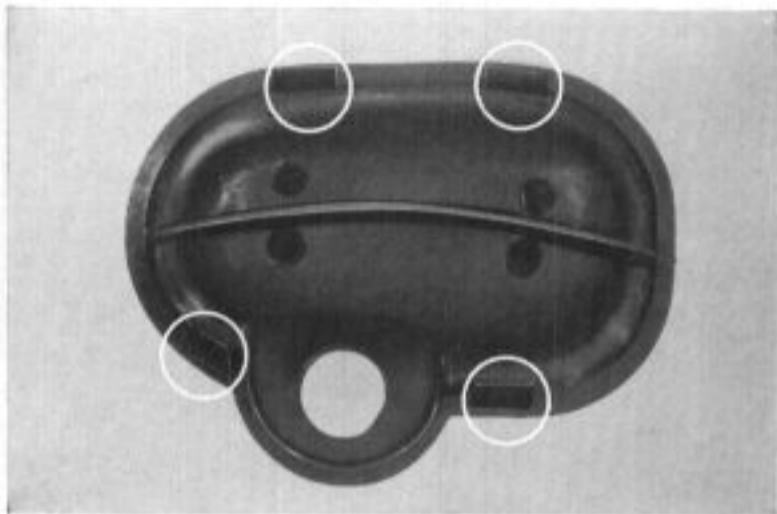

Fig. 18E-19

12. Install the lock lever housing. The housing has four claws which fit door panel.
Then, install the door lock lever with a screw.

13. Raise the door window fully by turning the temporarily installed regulator handle and reset the lever at the position shown in Fig. 18E-20 and secure with a retainer (Fig. 18E-21)

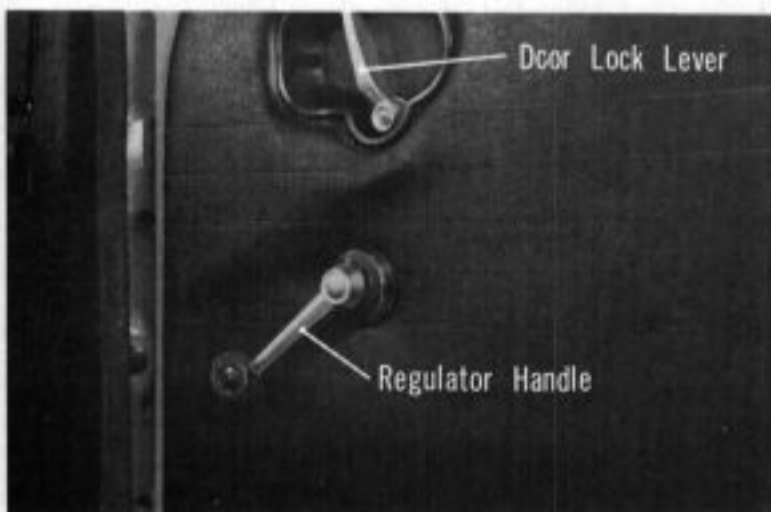

Fig. 18E-20

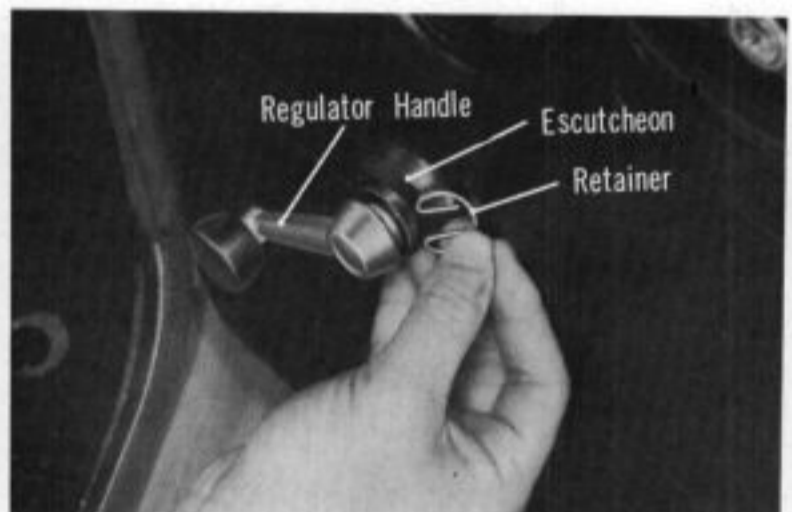
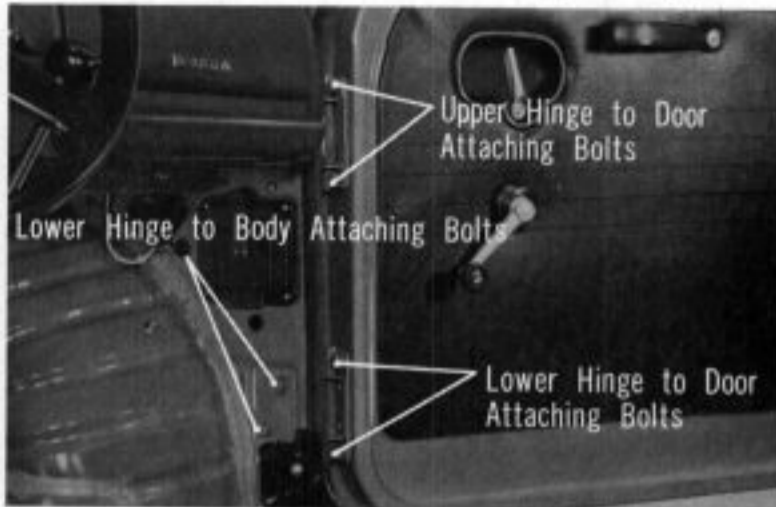

Fig. 18E-21

Installation

Although the door can be detached by removing either hinge-to-door bolts or hinge-to-body bolts, the door cannot be installed without attaching the hinges to the door.



Adjustment Fig. 18E-22

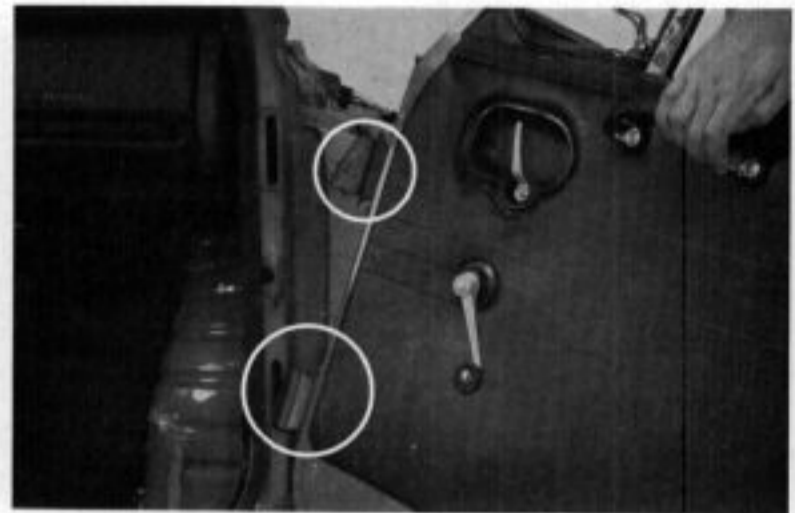

Fig. 18E-23

1. Door In/out, Up/Down, and Fore/Aft adjustment

In/Out, Up/Down, or Fore/Aft is provided at door hinge pillar and/or with adjusting shims.

- (1) For Fore/Aft adjustment, loosen the hinge-to-body attaching bolts and adjust the door.

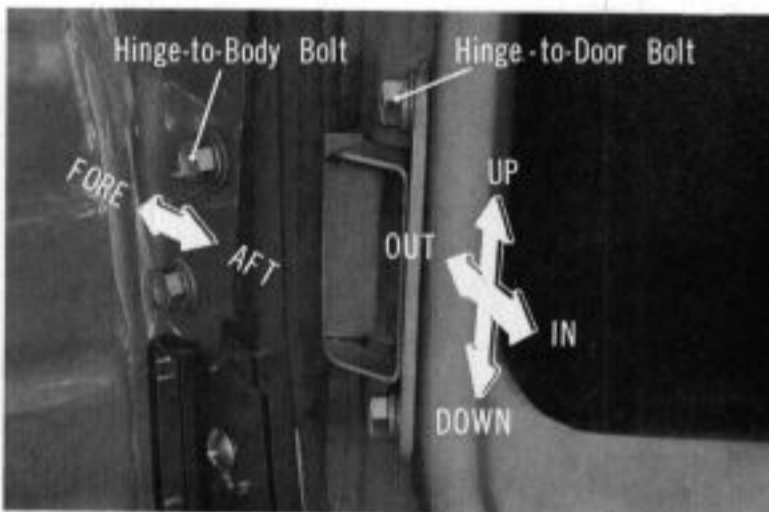

Fig. 18E-24

- (2) For In/Out or Up/Down adjustments, loosen the hinge-to-body bolts and adjust the door.

If the door is beyond this adjustment, use adjusting shims (Fig. 18E-25)

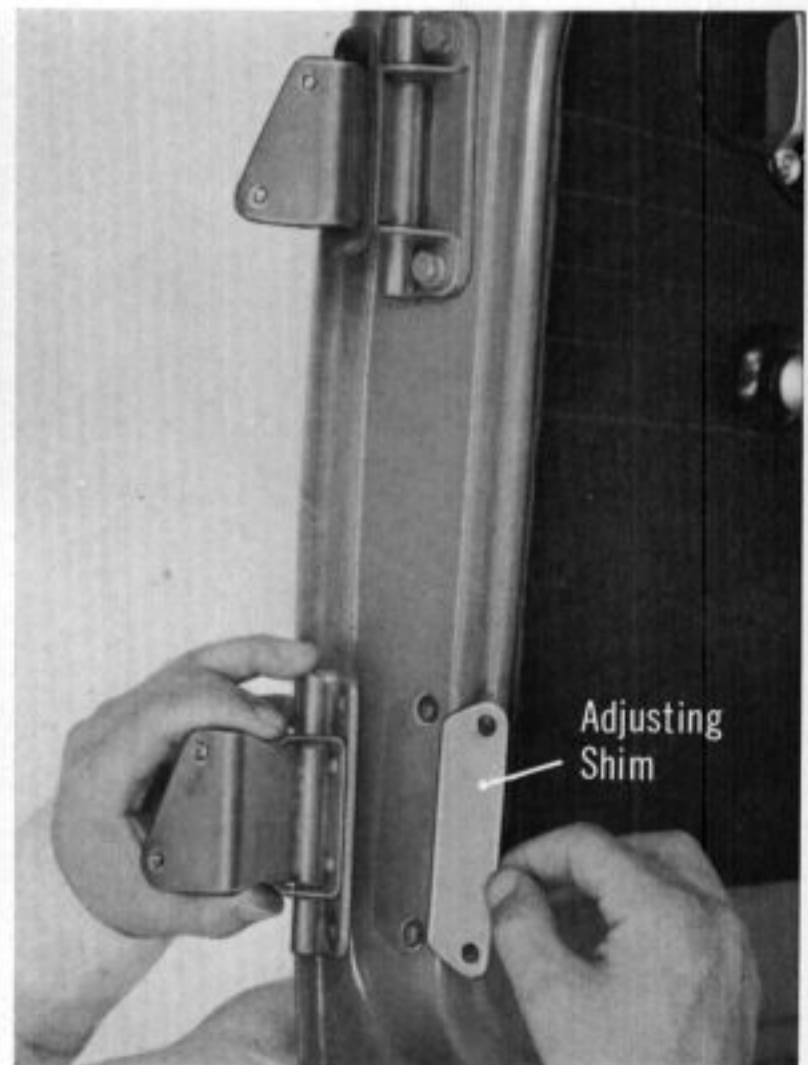

Fig. 18E-25

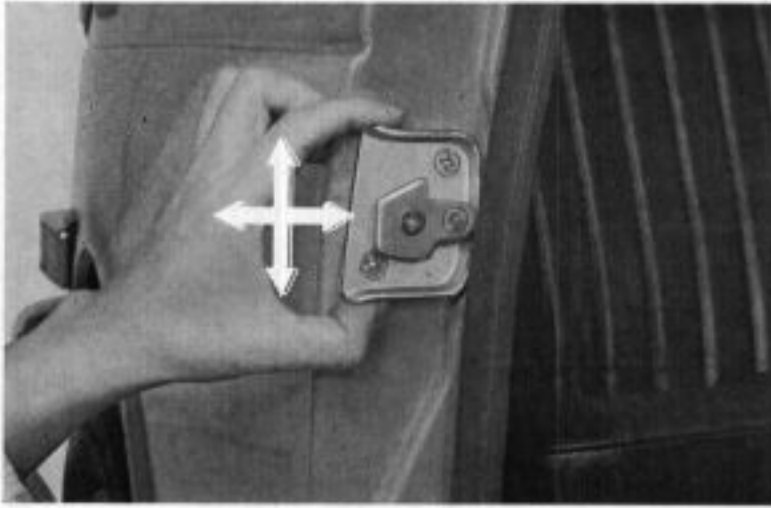

Fig. 18E-26

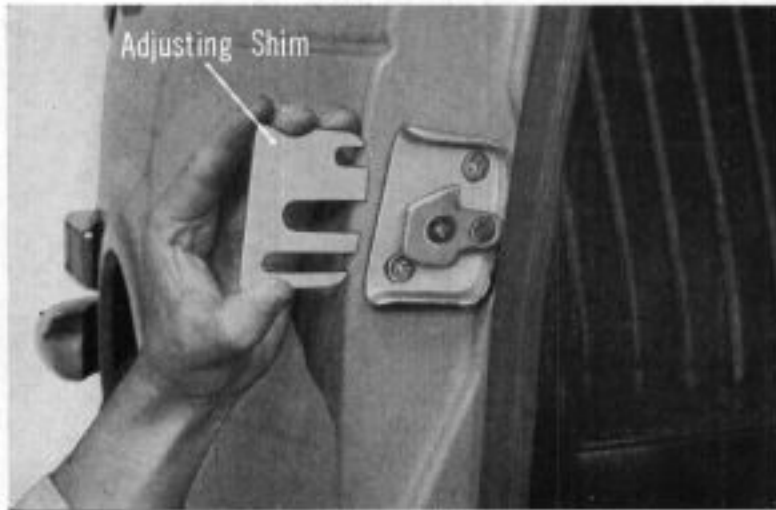

Fig. 18E-27

2. Door Open/Close action adjustment.

- (1) If the door does not close completely and opening/closing is not firm, slide the striker plate toward the inside to increase the door closing stroke. Conversely, if the door closing stroke is too deep and it is hard to close the door, slide the striker plate toward the outside.

Open and close the door slowly, while checking striker contact. If there is contact at the bottom (top) of the striker, lower (raise) the striker plate slightly. Repeat this operation until the door opens and closes smoothly.

- (2) When the door lock roller and striker are shifted toward the front and door closing action is poor, adjust with shims.

F. LN360 Tale Gate

There are two type LN360s which are distinguished by the type of tail gate used. The single tail gate type has a single unit tail gate hinged at the right, and thus open/close is made horizontally. The dual tail gate type has two independent tail gates, an upper and a lower, as shown in the figure.



Fig. 18F-1

a. Lower Tail Gate

The lower tail gate is mounted with two hinges and two supporters on both sides. To adjust the gate position, loosen the hinge bolts and slide the hinge to the proper position. Hinge holes are made large to allow adjustment. The lower tail gate panel is mounted with eight screws.

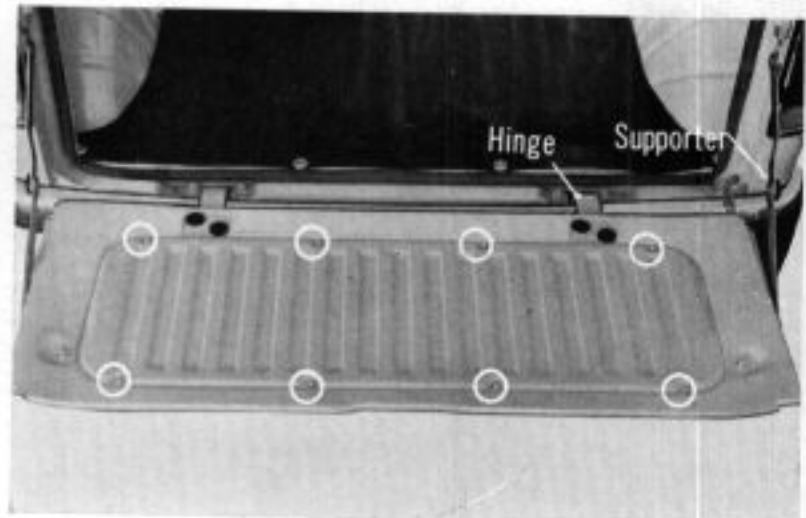

Fig. 18F-2

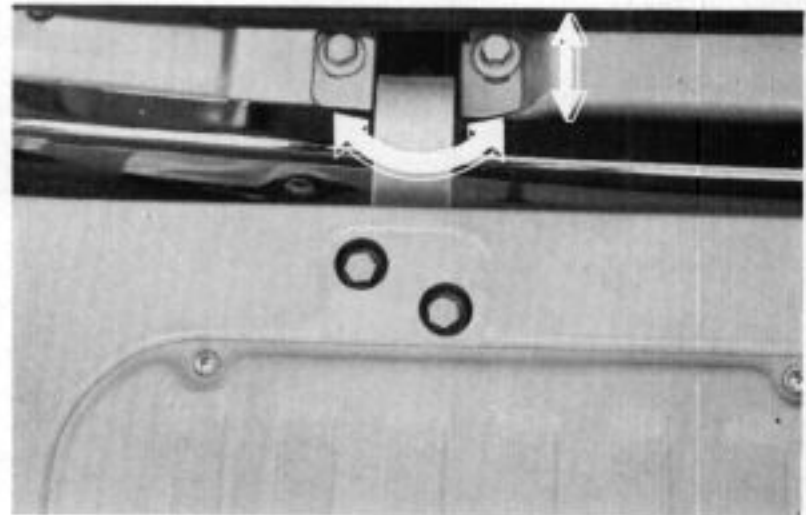

Fig. 18F-3

When opening or closing action of the lower is too firm or too soft, the probable cause is improper door striker positioning or a gate lock malfunction. Striker holes are made large to allow adjustment.



Fig. 18F-4

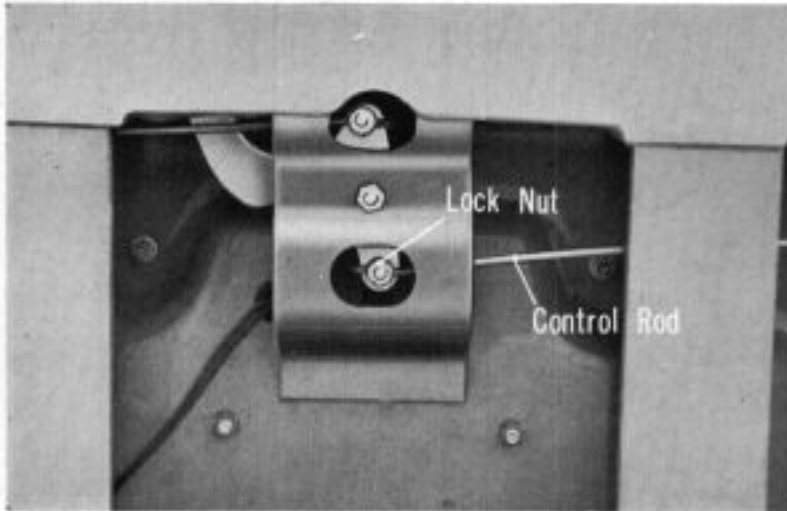

Fig. 18F-5



Fig. 18F-6



Fig. 18F-7



Fig. 18F-8

To repair the gate lock, remove the eight tail gate panel mounting screws, shown in Fig. 18F-2. Loosen the lock nut and adjust the length of the rods.

b. Upper Tail Gate

The upper tail gate is mounted with two hinges and supported with expansion supporter. Repositioning of the gate is accomplished by loosening the hinge bolts on the gate.

Rubber bellows are installed between the gate and the roof panel to prevent water drip when the gate is opened. Unlock the ten lock plates to remove the bellows.

To test gate closing action, free the tail gate from the horizontal opening position. The gate should close and lock without further effort.

If the gate does not close completely or if it closes "weakly", slide the striker to the correct position.

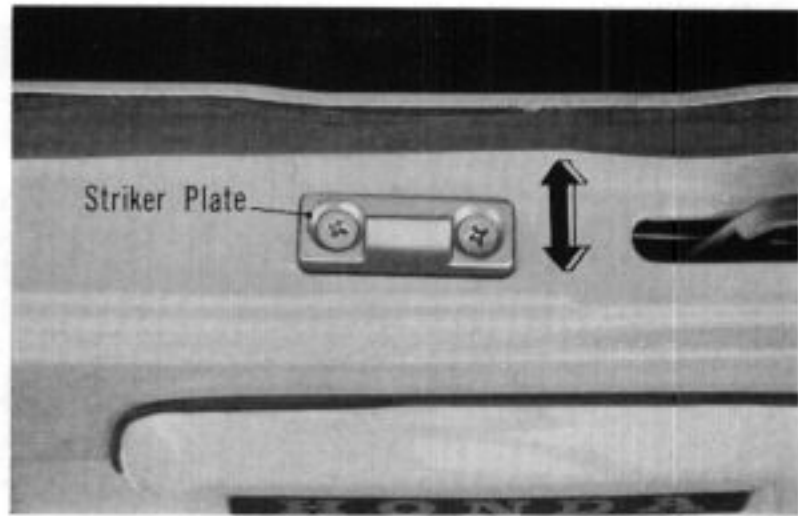

Fig. 18F-9

G. Windshield Glass

Fit weatherstrip to the glass. Place a 3.5 meter (11.5 ft) draw cord with a diameter of 6mm (0.236 in) in the groove. Apply rubber lubricant such as soap water to weatherstrip to make the installation easy.

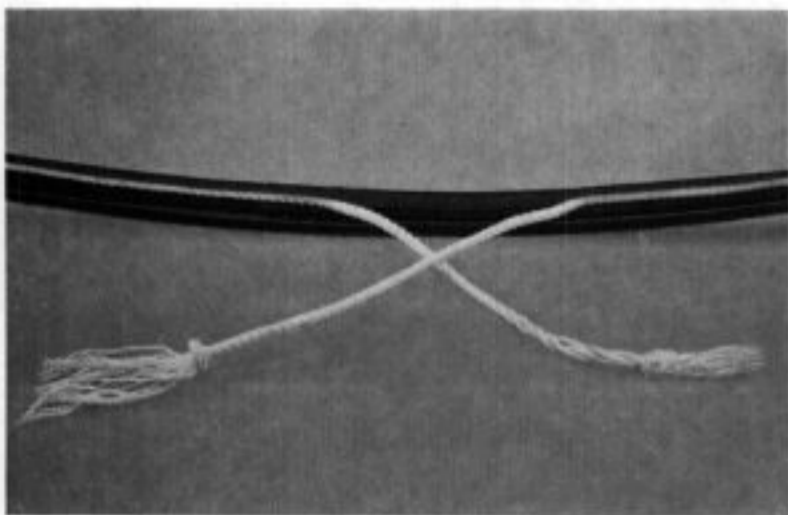

Fig. 18G-1

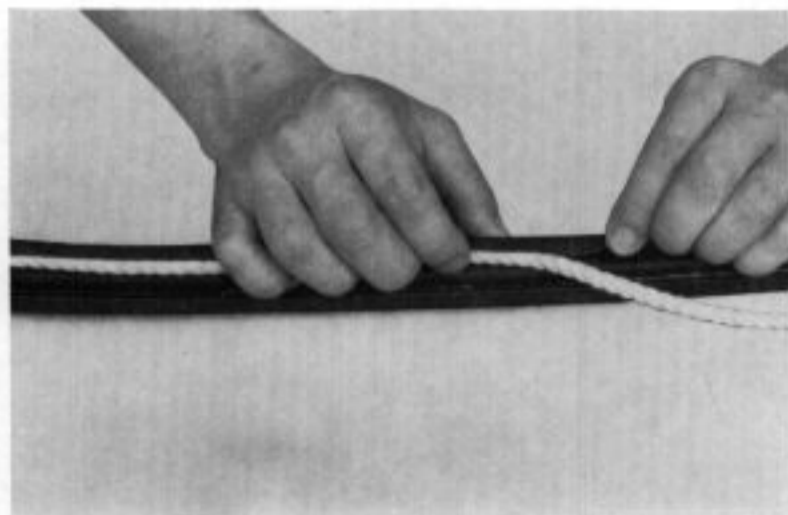

Fig. 18G-2



Fig. 18G-3

Insert the draw cord ends into the vehicle interior, force the windshield against the body directly by hand without using a hammer, and slowly pull out the rope. Two workers are required.

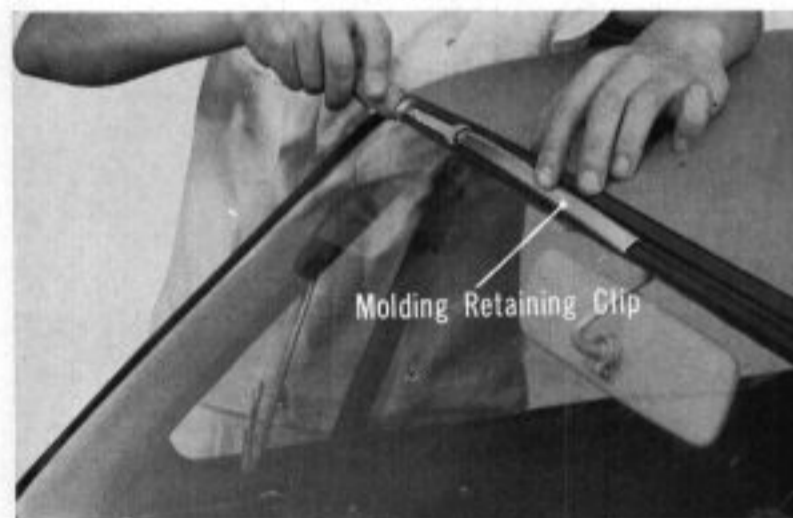

Fig. 18G-4

After insuring that weatherstrip is correctly positioned, squeeze rubber lubricant into the groove at molding retaining clips. Using the tool shown in Fig. 18G-4 or a screwdriver, spread the groove and fit molding retaining clips.

H. Windshield Washer

The windshield washer consists of the container bag which is suspended at the left front portion of the engine compartment, and nozzle located at the center of the bonnet, and the bulb (There are two types as shown in Fig. 18H-2 and Fig. 18H-3.)

Installed at the instrument panel.

No power is required to operate the washer. The washer operates when the bulb is depressed by hand several times. (Principle of water pump applies.)



Fig. 18H-1



Fig. 18H-2

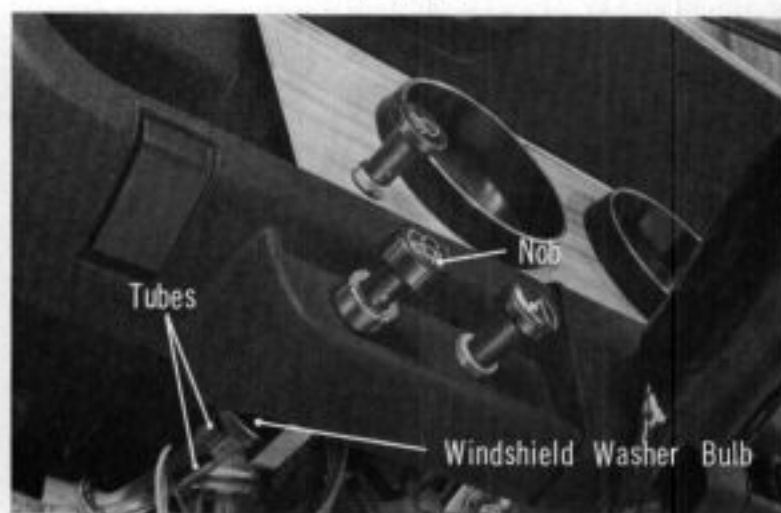

Fig. 18H-3

For the removal of windshield wiper/washer unit, use special tool.

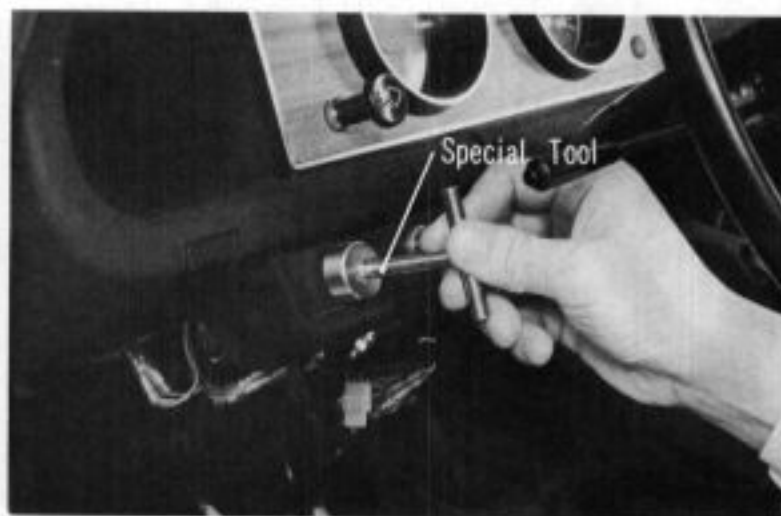

Fig. 18H-4

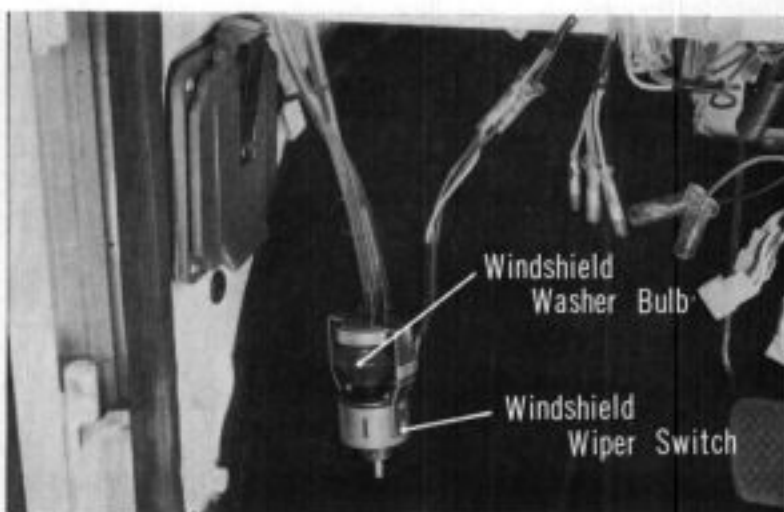

Fig. 18H-5

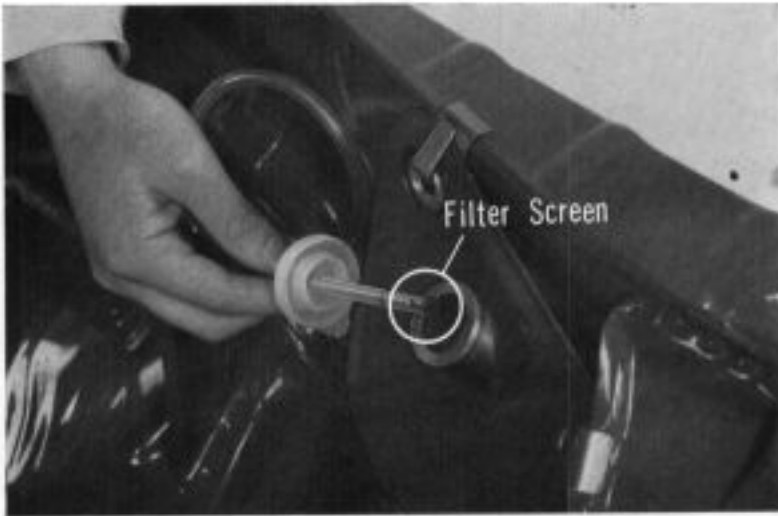

Fig. 18H-6

If the washer does not work, check the filter screen for clogging.

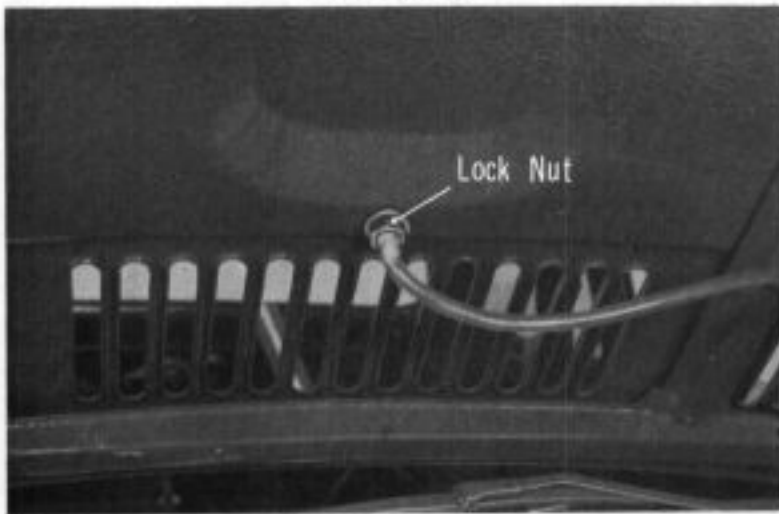

Fig. 18H-7

Make adjustment of the nozzle direction by loosening the lock nut when improper.

I. Quarter Window Glass

The quarter window glass is suspended by a channel hanger with two corrugated springs inserted into body slits. The bottom is secured with the quarter window lock assembly and opens with the channel hanger acting as a hinge.

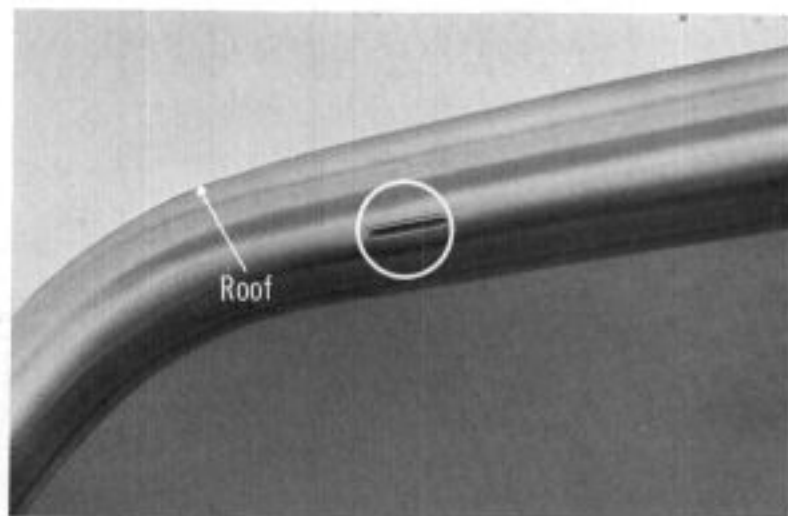

Fig. 18I-1

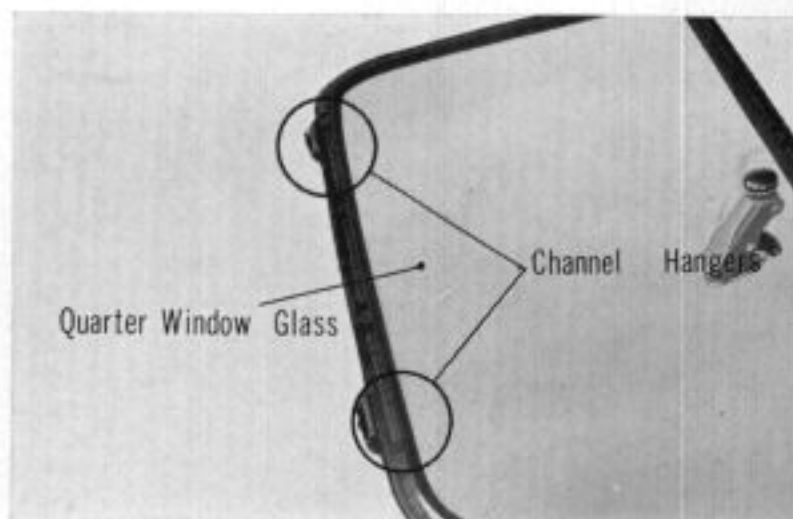

Fig. 18I-2

When disconnecting the quarter window lock assembly from the body, be sure not to drop the window.

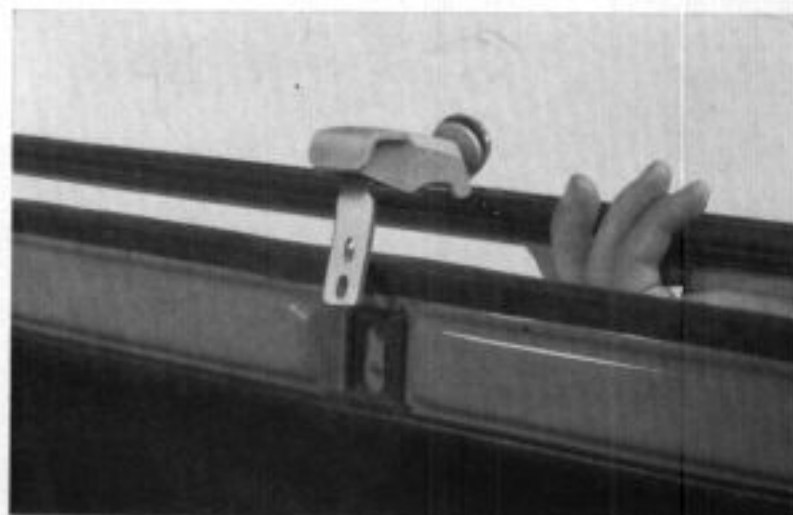

Fig. 18I-3

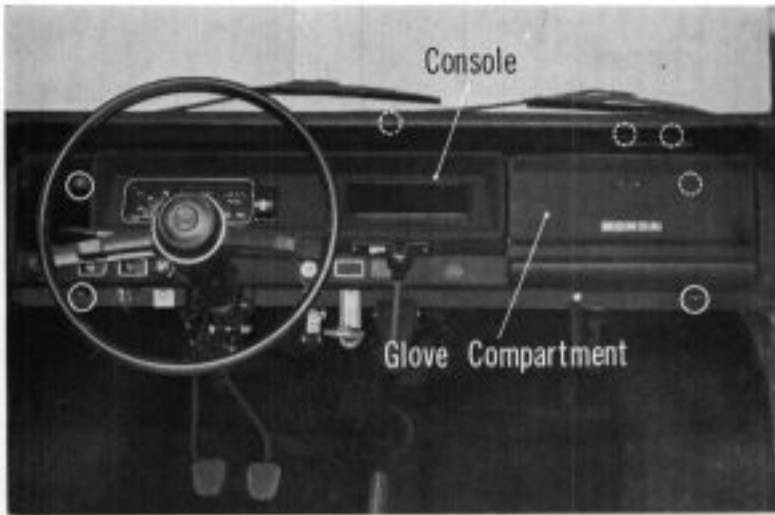

Fig. 18J-1

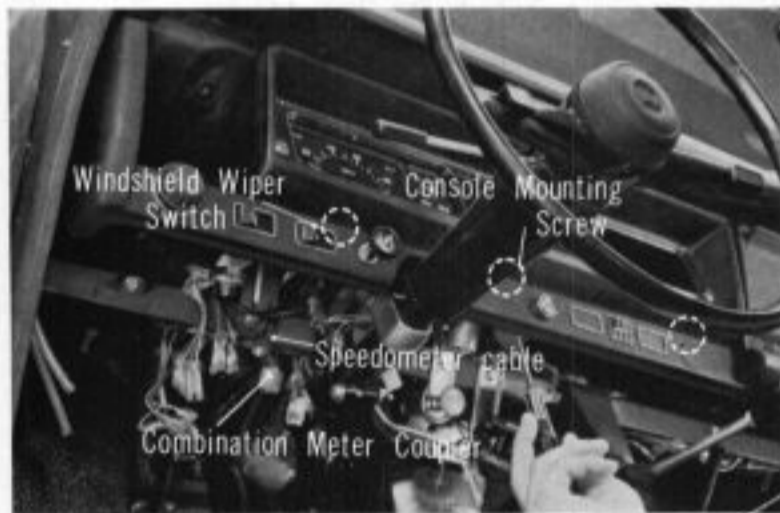

Fig. 18J-2



Fig. 18J-3



Fig. 18J-4

J. Standard Instrument Panel

The instrument panel is made of ABS resin material and trimmed with non-reflecting padded material to protect the driver in case of accident. The instrument panel assembly consists of instrument console, glove compartment and instrument panel.

a. Instrument Console

1. Removal of instrument console

Disconnect the electrical wiring coupler of the combination meter, and the speedometer cable. Remove the three console mounting screws. Note that the left screw cannot be removed with some models unless the windshield wiper switch is first removed.

Also disconnect the speedometer cable and heater/defroster select cable at the valve end.

Slide the console assembly about 20mm (0.80 in) outward.

Separate the console from the instrument panel. Note that the console cannot be removed from the instrument panel unless the console locking with sliding rail on the instrument panel are released.

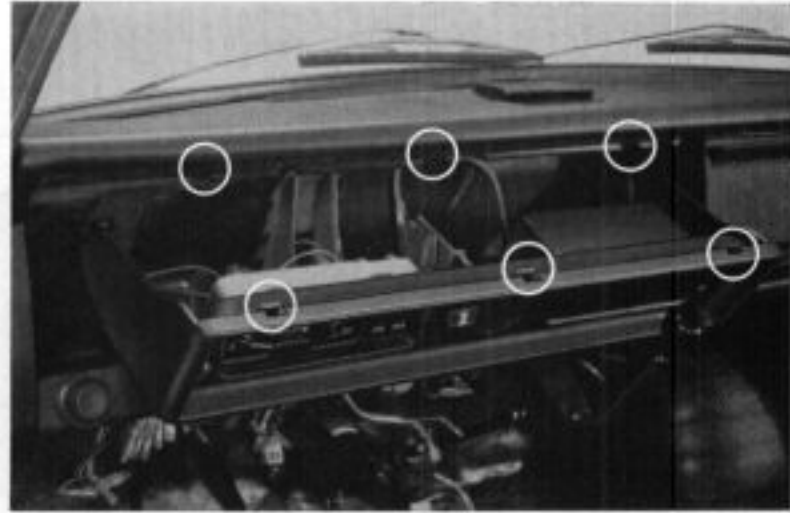

Fig. 18J-5

2. Removal and disassembly of combination meter.

To separate the combination meter from the console, remove the five screws shown in the figure. Do not drop the glass when separating the meter assembly.

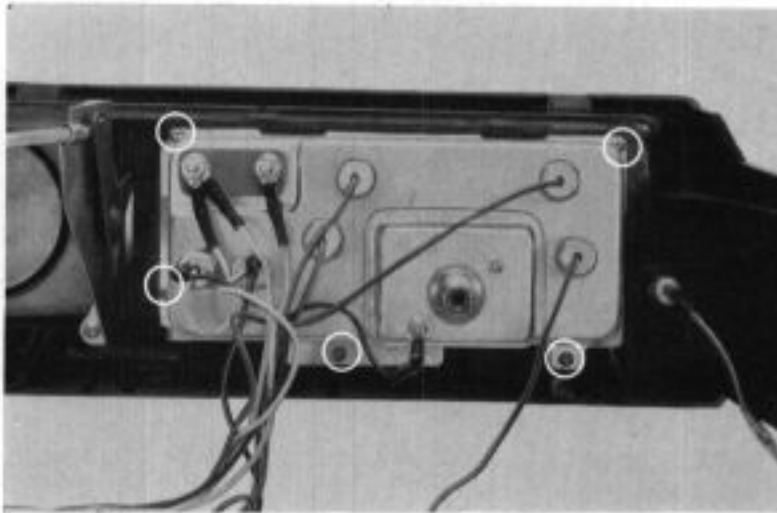

Fig. 18J-6

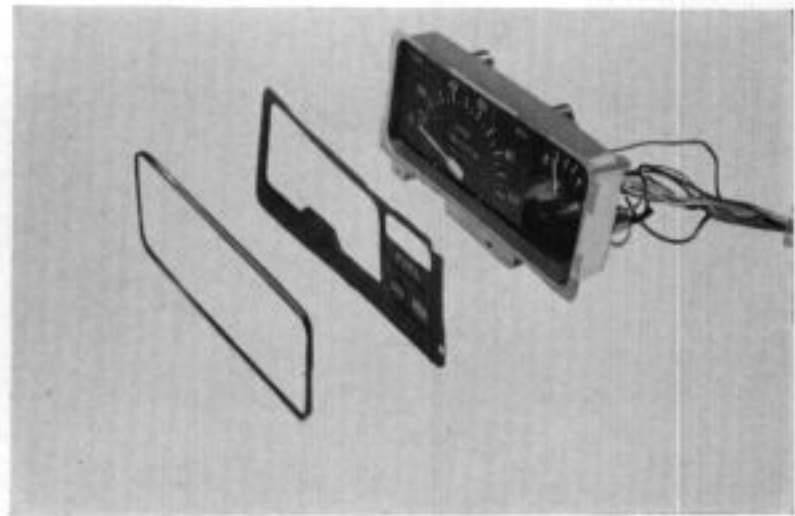

Fig. 18J-7

Turn the pilot lamps counterclockwise to remove.

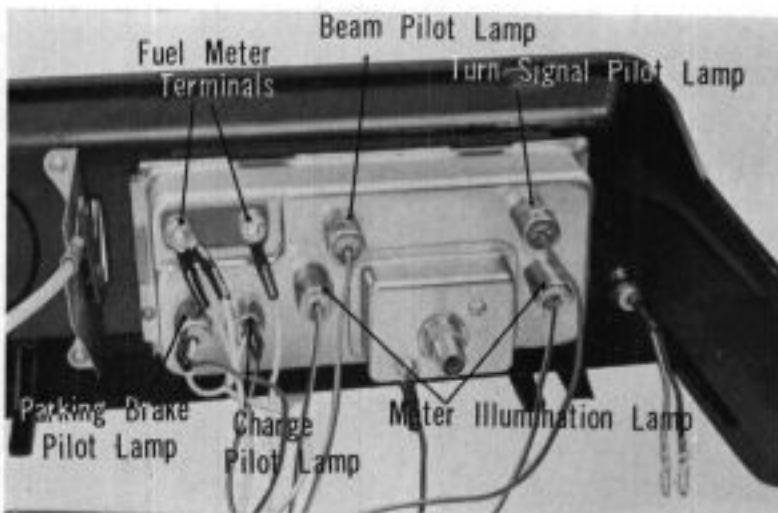

Fig. 18J-8

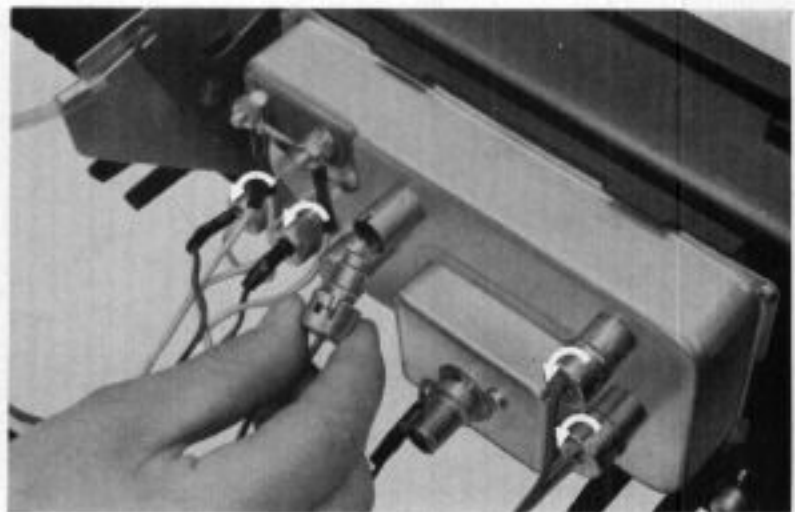

Fig. 18J-9

b. Glove Compartment

To disassemble the glove compartment, remove the two color-matching screws and slide the glove compartment about 20mm (0.80 in) inward. Note that the glove compartment cannot be separated from the instrument panel unless the glove compartment claws are released (The claws lock the sliding rails of the instrument panel).

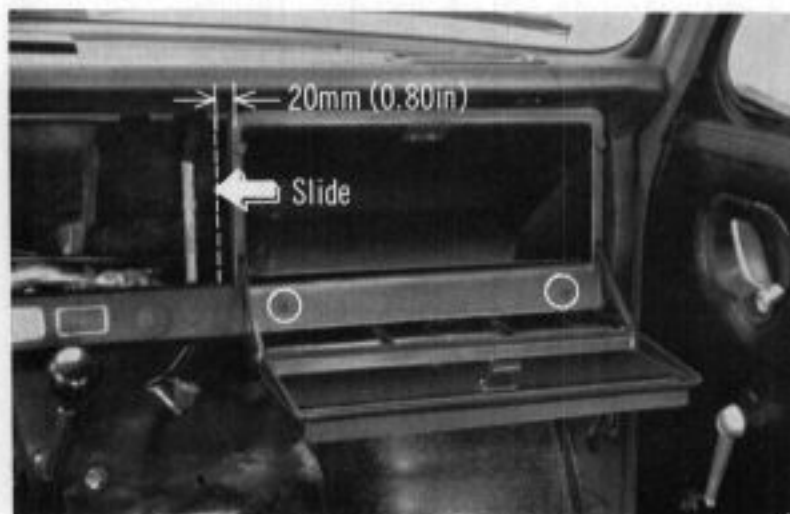

Fig. 18J-10



Fig. 18J-11

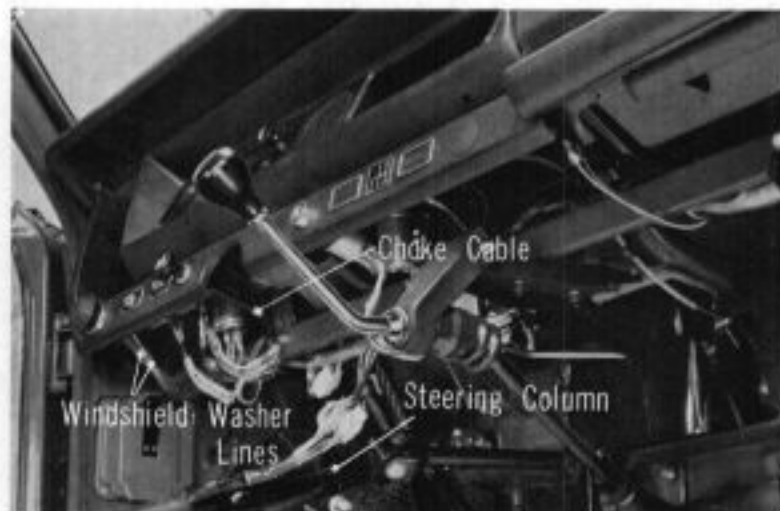

Fig. 18J-12

c. Instrument Panel

1. Removal of instrument panel

- * Disconnect all electrical wirings.
- * Dismount the steering column assembly from the bracket and lay down on the floor.
- * Remove the console assembly and glove compartment. (Refer to section "console" and "glove compartment.")
- * Disconnect the choke cable at the carburetor end and extract the cable inside the passenger room.
- * Disconnect the windshield washer lines.

* Remove the instrument panel mounting screw beneath the ashtray. To remove the ashtray, first lift at the front to unlock the ashtray mounting spring and then slide ahead.



Removal Sequence of Ashtray

Fig. 18J-13



Fig. 18J-14

- * Remove two instrument panel mounting screws at the passenger grip. Do not lose cushion rubbers fitted in the screws (Fig. 18J-21)

The grip is made of polypropylene. Squeeze the grip and lift by a screwdriver for removal.

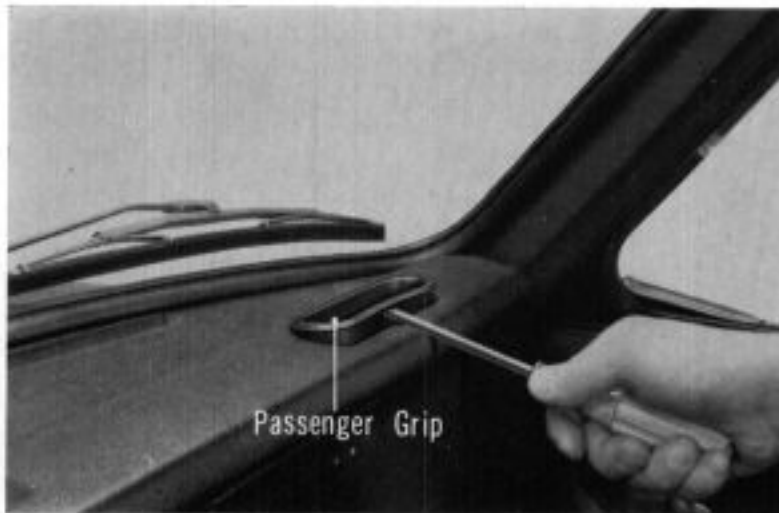

Fig. 18J-15



Fig. 18J-16

- * Remove the rest of three mounting screws, then the instrument panel is ready for removal.

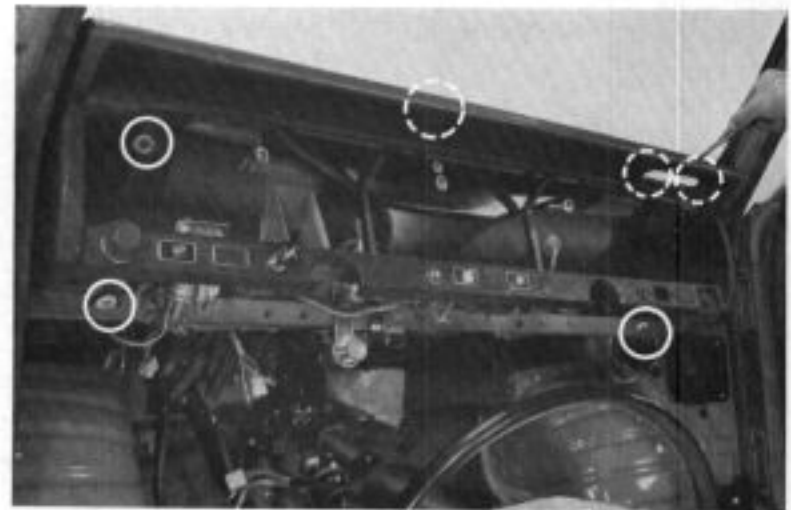

Fig. 18J-17

2. Assembly of the instrument panel.
Fit the top crash pad onto the instrument panel.

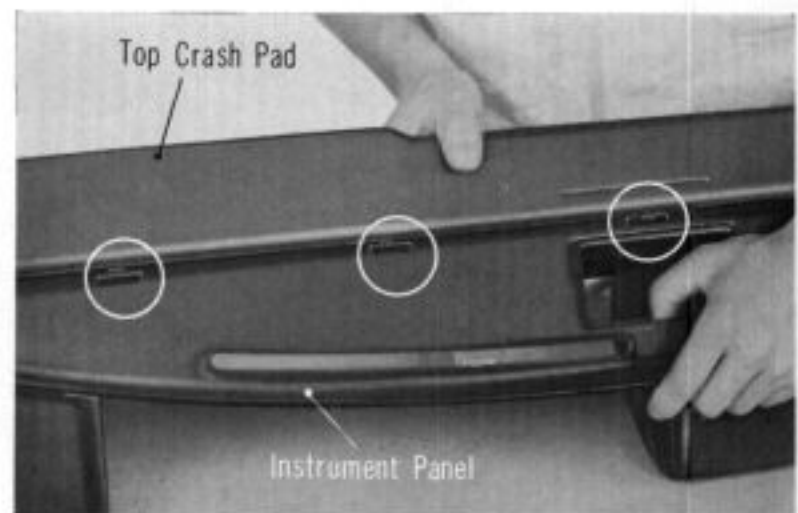

Fig. 18J-18

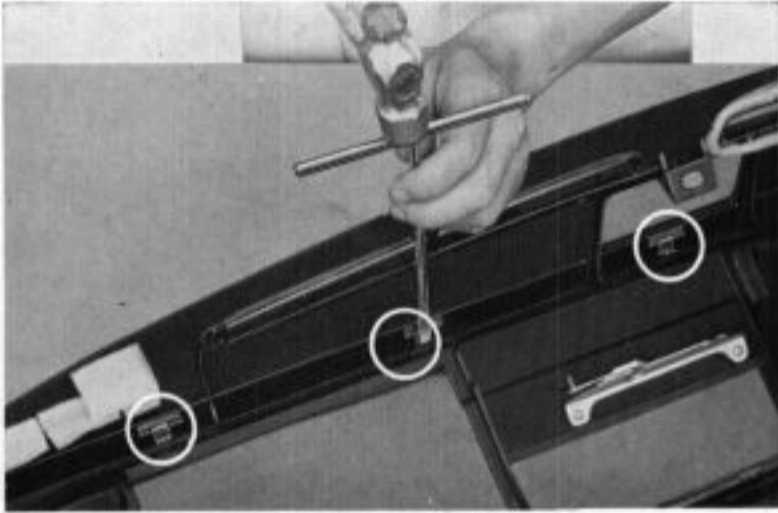

Fig. 18J-19

If hooking is not made correctly, the pad becomes slack. Bend the hooks carefully.



Fig. 18J-20

Fit the glove compartment bottom crash pad to the instrument panel. Bend hooks carefully.

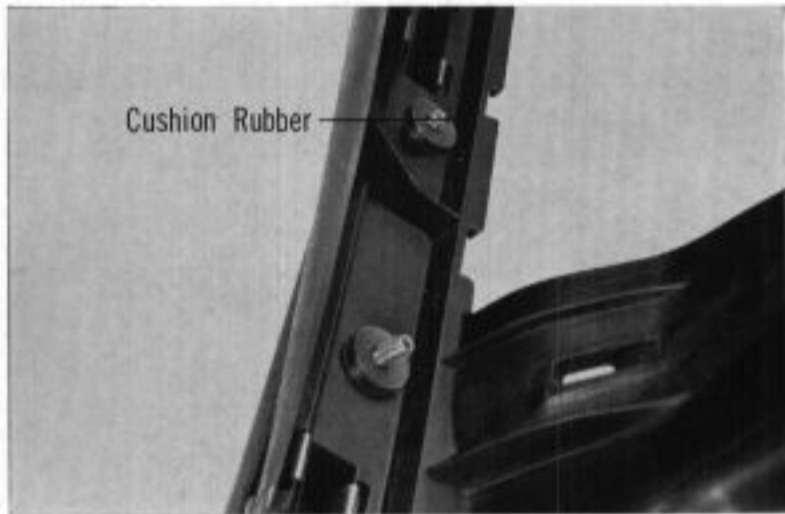

Fig. 18J-21

Install the instrument panel on the dashboard. Make sure that the instrument panel is rubber mounted at the passenger grip.

Squeeze the grip using a screwdriver and fit into the instrument panel. Do not place the grip in the opposite direction.

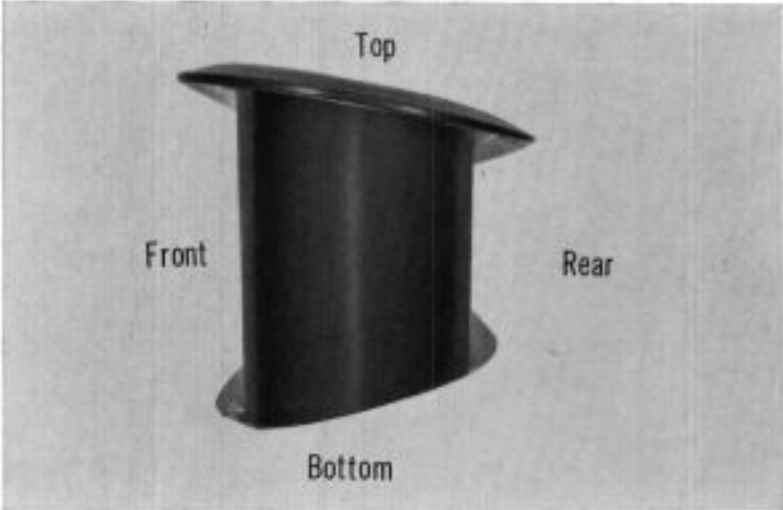

Fig. 18J-22

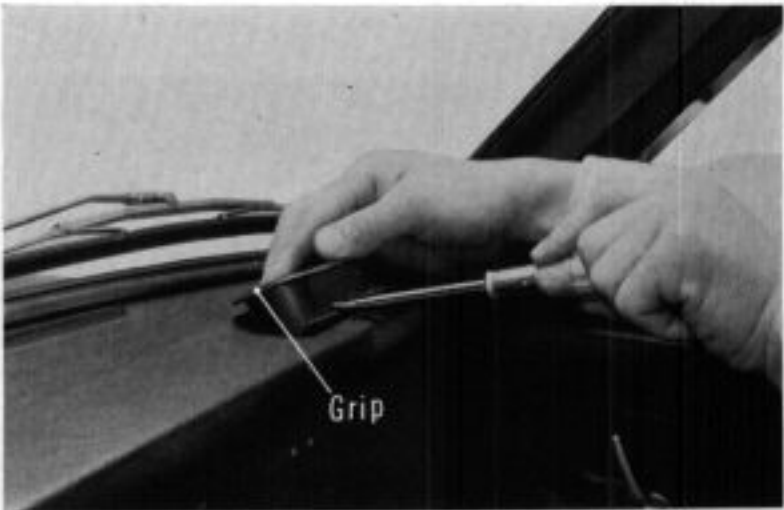

Fig. 18J-23

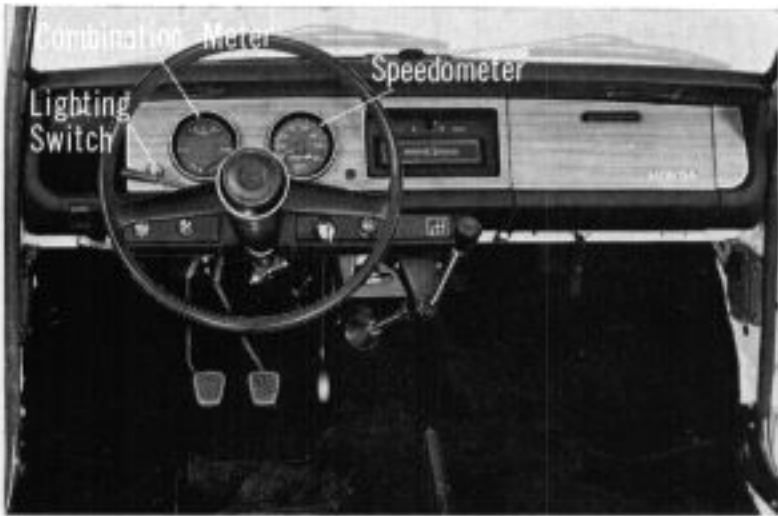

Fig. 18K-1

K. Deluxe Instrument Panel

The deluxe instrument panel consists of the circular speedometer, combination meter and the pull-type switches. The glove compartment of the deluxe instrument panel is of an integral construction with the instrument panel body and cannot be separated while the glove compartment of the standard instrument panel is independent and is fitted in the instrument panel.

a. Speedometer and Combination meter

Both the speedometer and the combination meter is fitted into the holes of the instrument panel and fixed with tension springs.

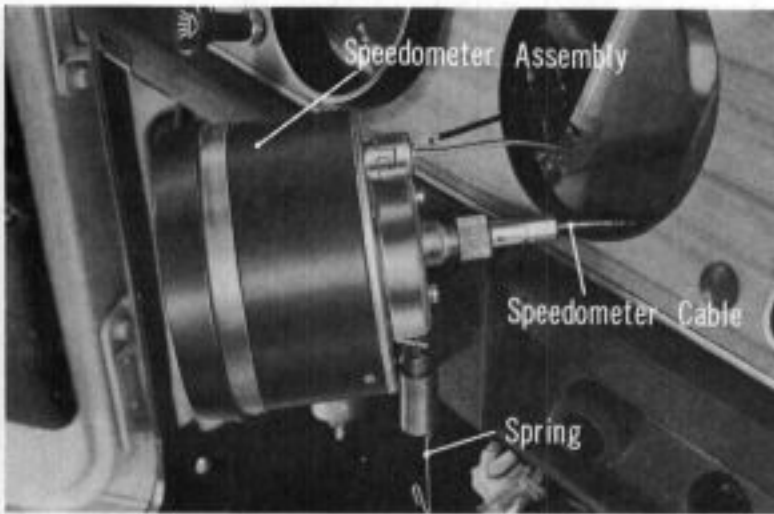

Fig. 18K-2

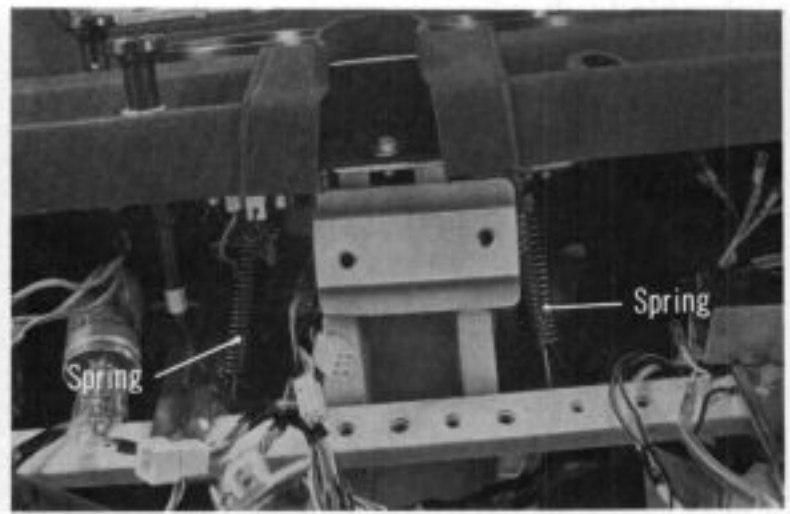

Fig. 18K-3

Turn the pilot lamps counterclockwise for the removal.

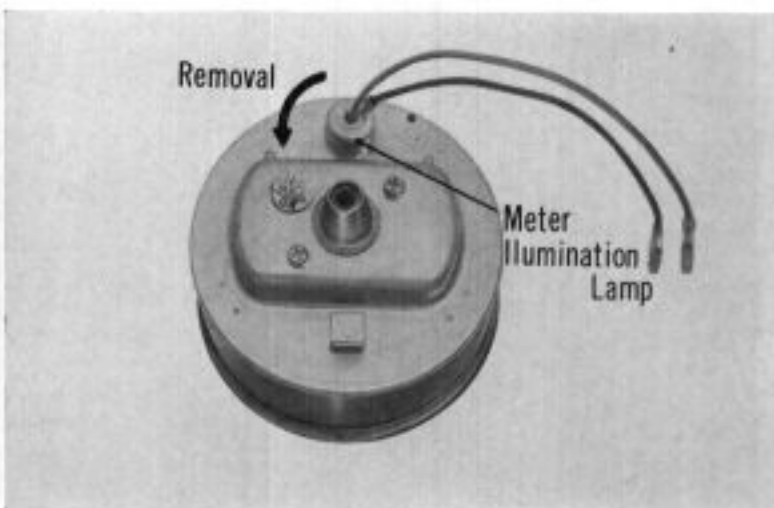

Fig. 18K-4-Speedometer

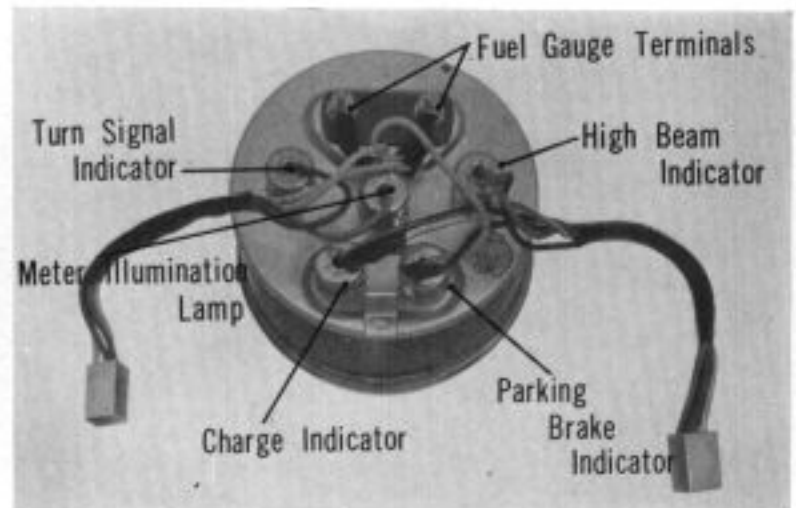

Fig. 18K-5-Combination meter

b. Instrument panel

1. Removal of instrument panel assembly

- * Disconnect all electrical wirings.
- * Dimount the steering column assembly from the bracket and lay down on the floor.
- * Disconnect the windshield washer lines.
- * Disconnect the choke cable at the carburetor end and extract the cable inside the passenger room.

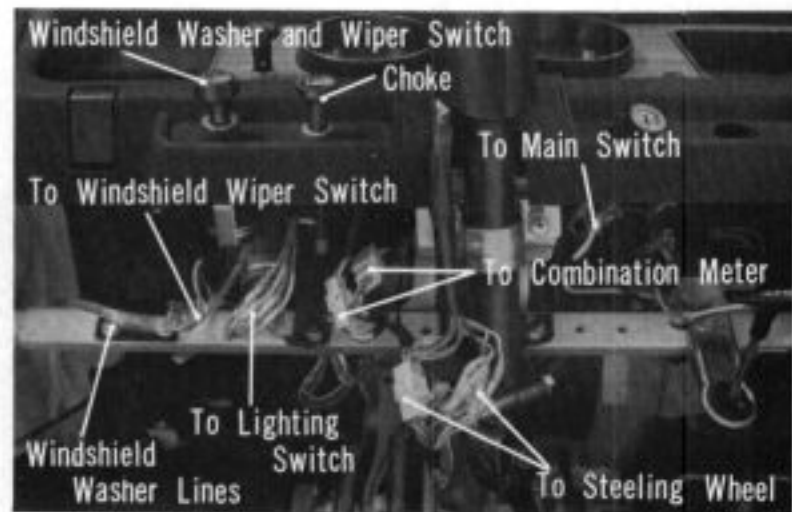

Fig. 18K-6

- * Remove six mounting screws to detach the instrument panel assembly from the dashboard.

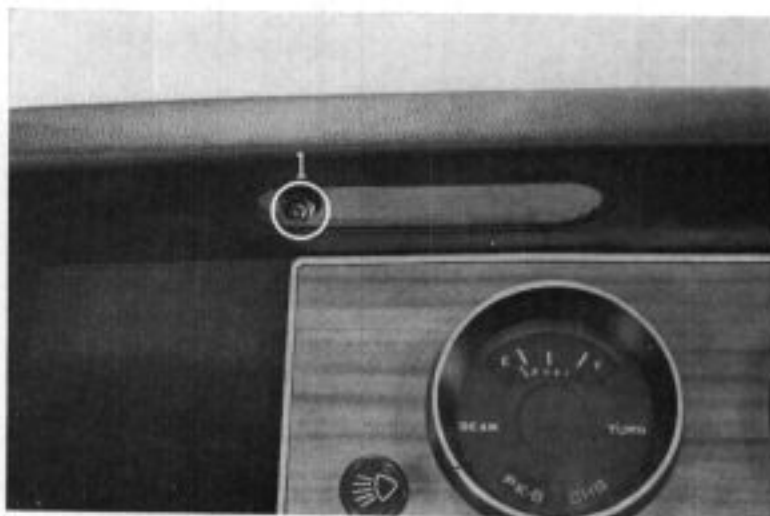

Fig. 18K-7



Fig. 18K-8

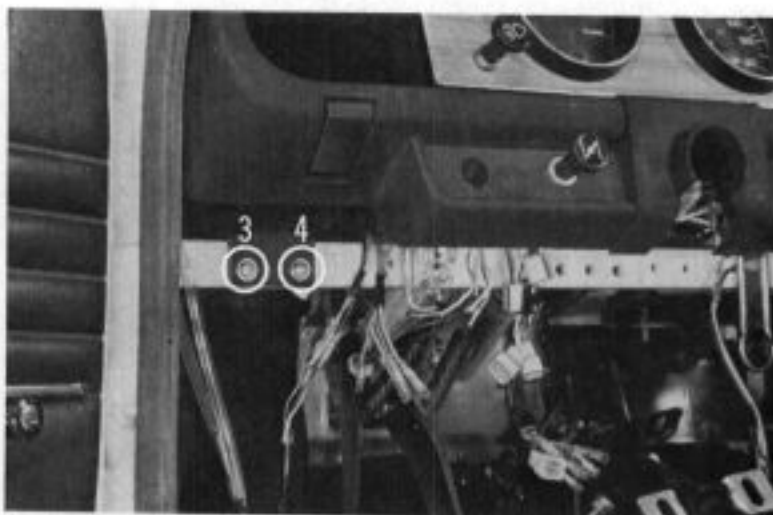

Fig. 18K-9

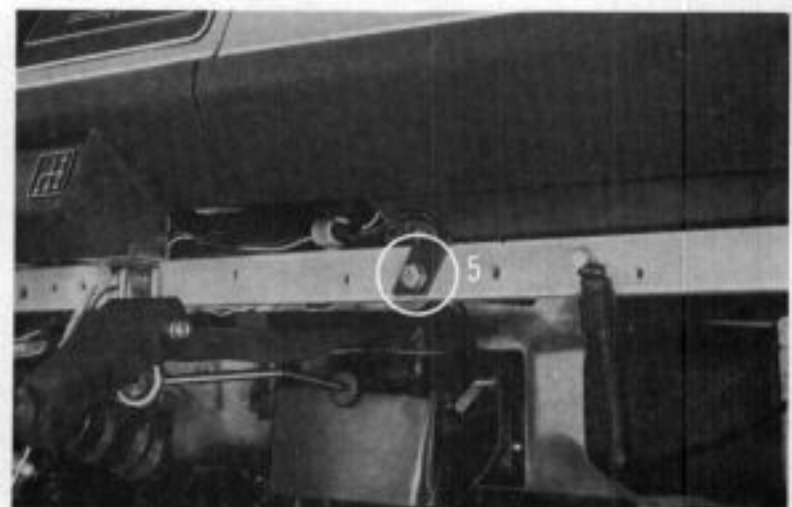

Fig. 18K-10



Fig. 18K-11

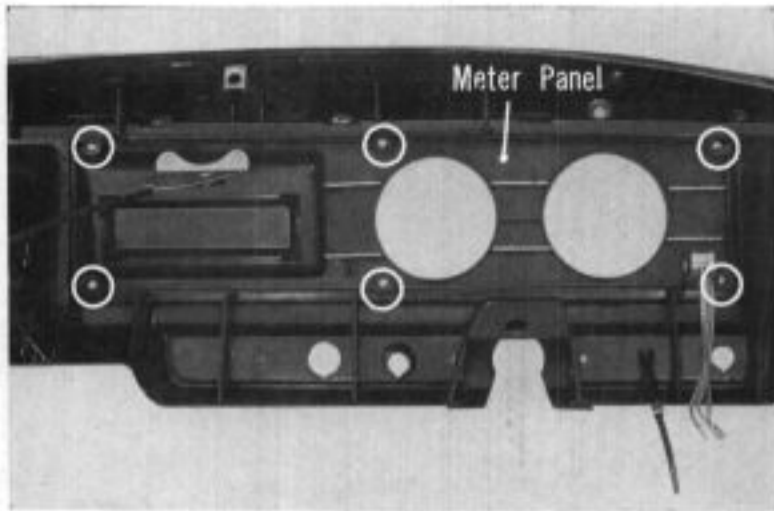

Fig. 18K-12

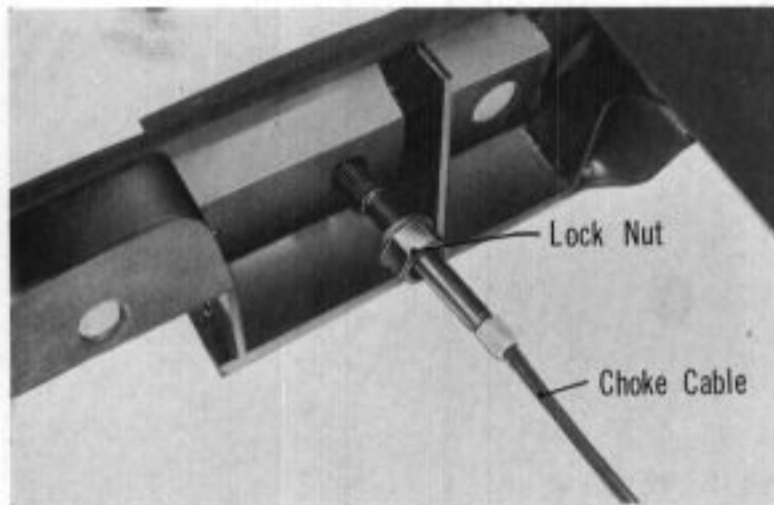

Fig. 18K-13

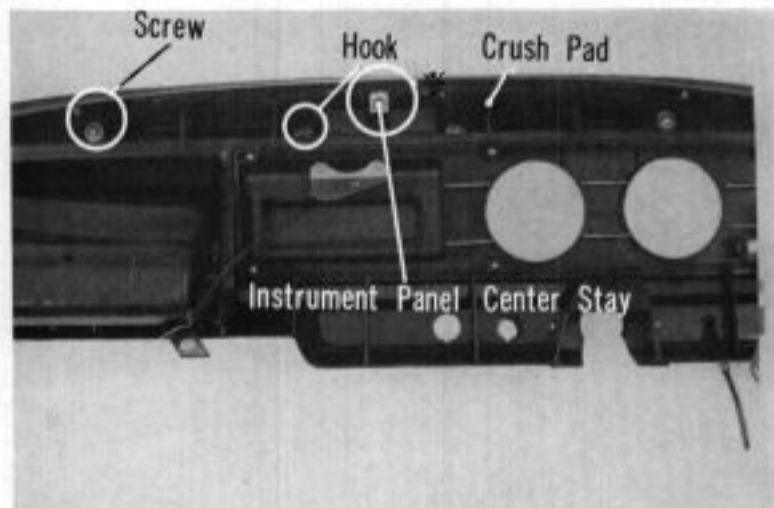

Fig. 18K-14

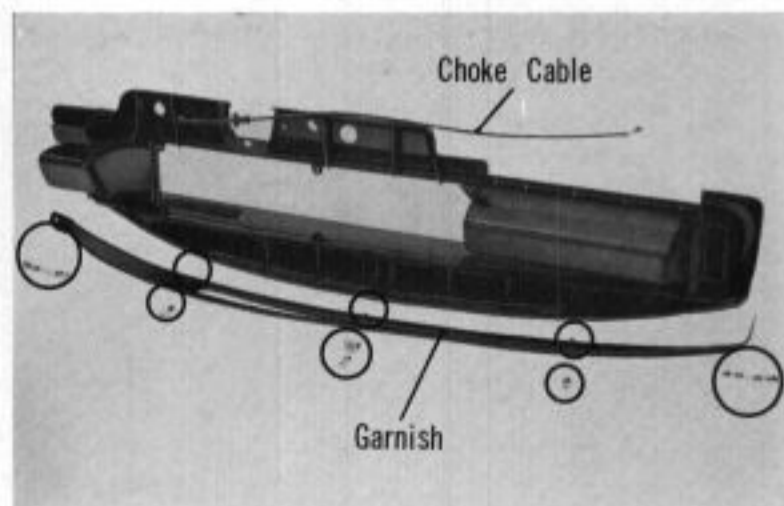

Fig. 18K-15

2. **Disassembly of meter panel**
Remove six mounting screws.

3. **Removal of choke cable**
Loosen the lock nut and extract the choke cable from the instrument panel.

4. **Assembly and installation of instrument panel**
* Assemble the crash pad to the instrument panel with screws and hooks.

- * Assemble the garnish to the instrument panel with five screws.

* Fit the instrument panel center stay * in Fig. 18K-14 to the pin.

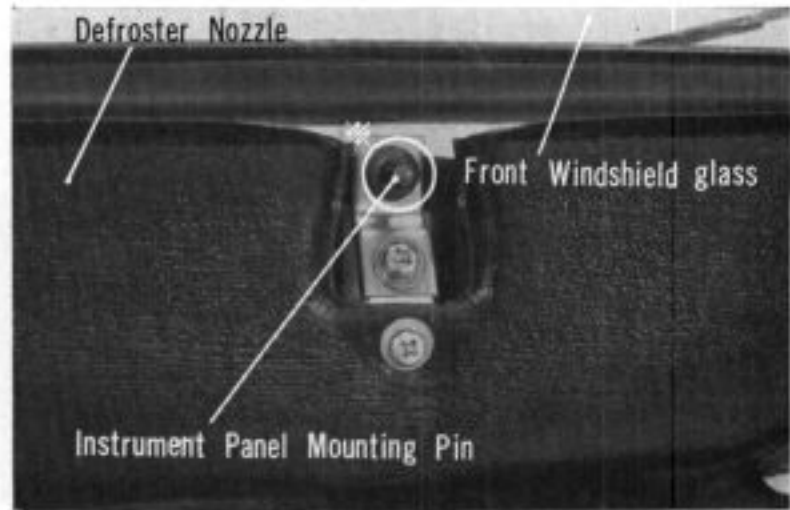

Fig. 18K-16

c. Glove Compartment

The glove compartment is a single unit with instrument panel and cannot be disassembled.

The glove compartment lid is attached to the instrument panel with a hinge and two support arm at both ends.

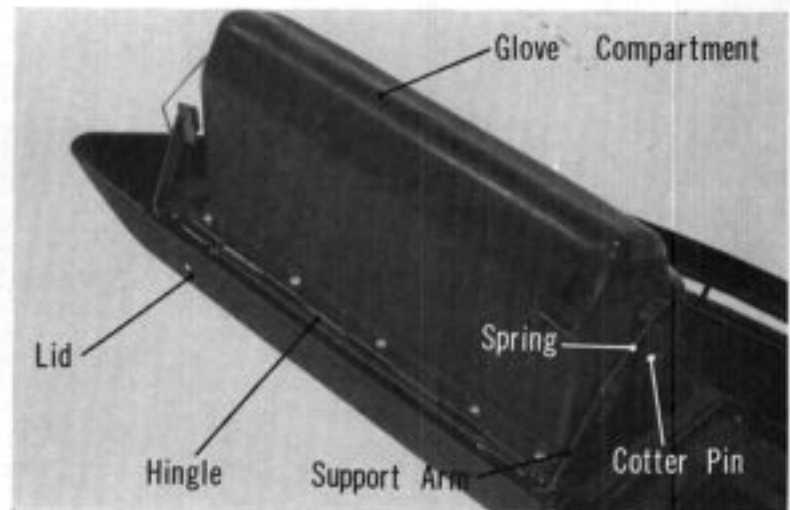

Fig. 18K-17

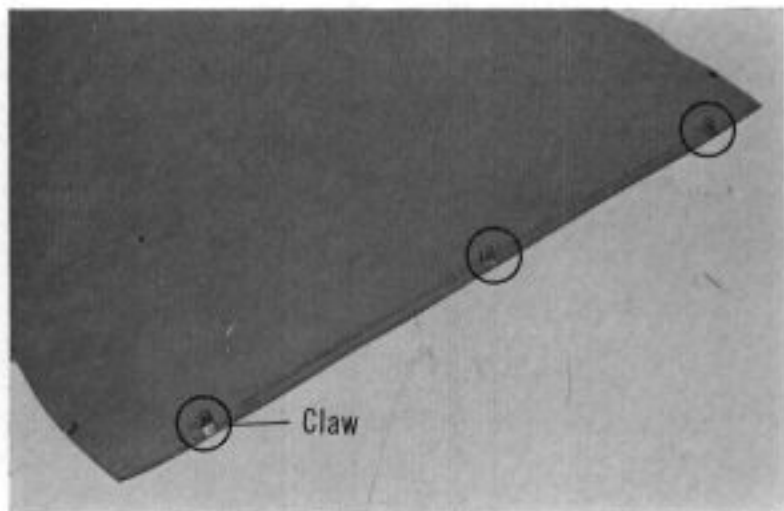

Fig. 18L-1

L. Body Accessories

a. Top Lining

The lining has three claws, at the front and the rear, and by them it is secured to the roof panel. On the other hand, both sides of the lining is supported by merely being fitted in the groove on the body side panel.

To remove or install the lining, use a special tool. When installing or removing, place the tool aside the claw. Never place the tool on the claws since the tool bends the claws and drives them deep into the frame. This results in difficult unhooking. The location of the front end hooks is shown in Fig. 10L-3. The rear end claws are located in the center (one claw) and at the same position with the front end side claws (the remaining two claws).

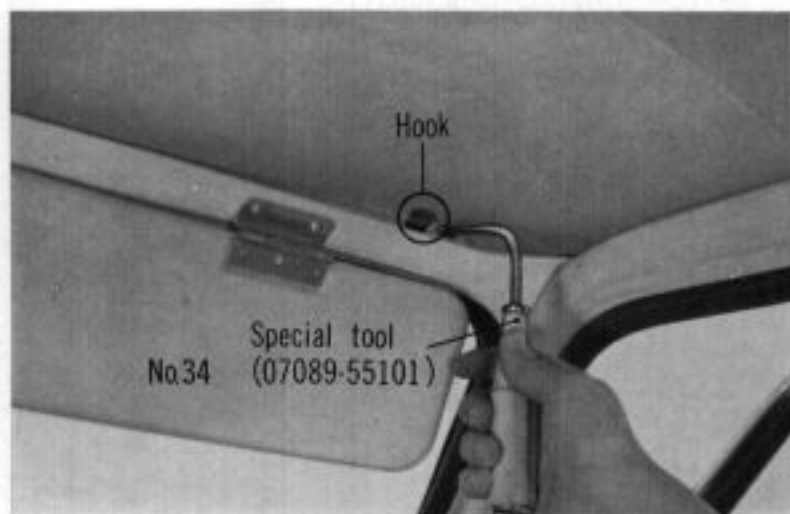

Fig. 18L-2

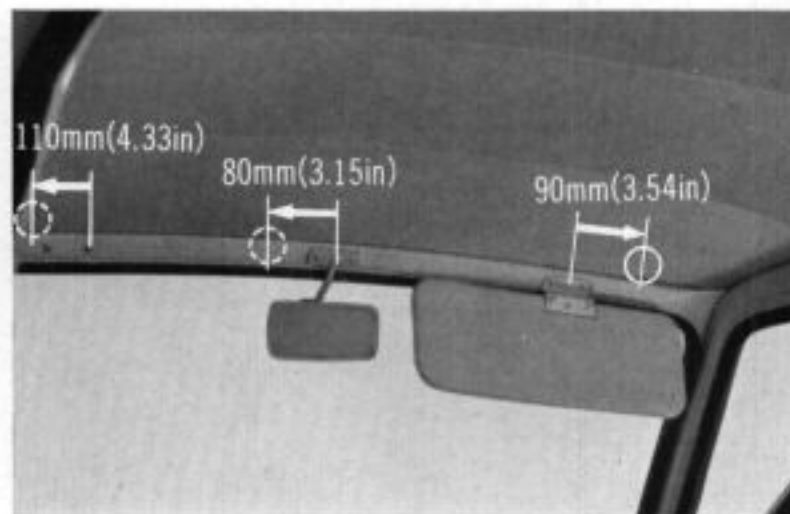

Fig. 18L-3



Fig. 18L-4

b. Rear Side Gadget Tray

The rear side gadget tray is made of polyethylene and can be detached from the body after unscrewing the two quarter window mounting screws. Extra care should be taken not to drop the quarter window when these screws are removed.

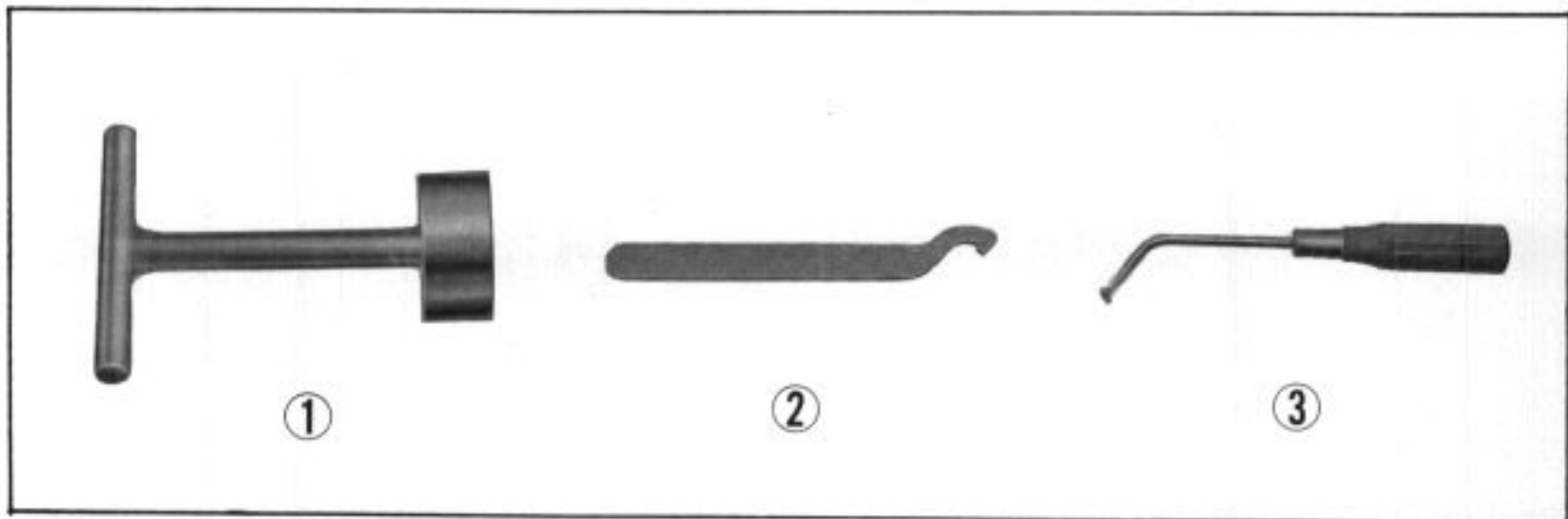
M. Special Tool

Ref. No.	Tool No.	Description
1.	07071-56801	Ignition switch wrench
2.	07076-59301	Lighting switch wrench
3.	07089-55101	Roof lining remover

M E M O

